

COLUMN 1 Number of percentage points by which the Developer has failed to achieve the Event Day Modal Split Target for Event Type B	COLUMN 2 Amount
Less than 0.1% to 0.9%	0 (zero)
1% to 1.9%	£100,000
2% to 2.9%	£200,000
3% to 3.9%	£300,000
4% or greater	£400,000

C = the amount (if any) determined by reference to Column 2 of the table below which is in turn determined by reference to Column 1 of the table below which shows the number of percentage points (rounded up to the nearest tenth of a percentage point) by which the Developer has failed to achieve the Event Day Modal Split Target for Event Type C (which is calculated by deducting the modal split for Event Type C that has been achieved during the relevant Non-Football Season (as set out in the Stage Three FEDTP Monitoring Report or any subsequent Full Event Day Travel Plan (Non-Football Season) Monitoring Report) from the Event Day Modal Split Target for Event Type C)

COLUMN 1 Number of percentage points by which the Developer has failed to achieve the Event Day Modal Split Target for Event Type C	COLUMN 2 Amount
Less than 0.1% to 0.9%	0 (zero)
1% to 1.9%	£100,000
2% to 2.9%	£200,000
3% to 3.9%	£300,000
4% or greater	£400,000

D = the amount (if any) determined by reference to Column 2 of the table below which is in turn determined by reference to Column 1 of the table below which shows the number of percentage points (rounded up to the nearest tenth of a percentage point) by which the Developer has failed to achieve the Event Day Modal Split Target for Event Type D (which is calculated by deducting the modal split for Event Type D that has been achieved during the relevant Non-Football Season (as set out in the Stage Three FEDTP Monitoring Report or any subsequent Full Event Day Travel Plan (Non-Football Season) Monitoring Report) from the Event Day Modal Split Target for Event Type D)

COLUMN 1 Number of percentage points by which the Developer has failed to achieve the Event Day Modal Split Target for Event Type D	COLUMN 2 Amount
Less than 0.1% to 0.9%	0 (zero)
1% to 1.9%	£75,000
2% to 2.9%	£150,000
3% to 3.9%	£225,000

COLUMN 1 Number of percentage points by which the Developer has failed to achieve the Event Day Modal Split Target for Event Type D	COLUMN 2 Amount
4% to 4.9%	£300,000
5% to 5.9%	375,000
6% or greater	£400,000

E = the amount (if any) determined by reference to Column 2 of the table below which is in turn determined by reference to Column 1 of the table below which shows the number of percentage points (rounded up to the nearest tenth of a percentage point) by which the Developer has failed to achieve the Event Day Modal Split Target for Event Type E (which is calculated by deducting the modal split for Event Type E that has been achieved during the relevant Non-Football Season (as set out in the Stage Three FEDTP Monitoring Report or any subsequent Full Event Day Travel Plan (Non-Football Season) Monitoring Report) from the Event Day Modal Split Target for Event Type E)

COLUMN 1 Number of percentage points by which the Developer has failed to achieve the Event Day Modal Split Target for Event Type E	COLUMN 2 Amount
Less than 0.1% to 0.9%	0 (zero)
1% to 1.9%	£100,000
2% to 2.9%	£200,000
3% to 3.9%	£300,000
4% or greater	£400,000

APPENDIX 2
DRAFT PLANNING PERMISSION



FULL MAJOR PLANNING PERMISSION

Town and Country Planning Act 1990

Town and Country Planning (Development Management Procedure) (England) Order 2010

Please see notes at the end of this notice

Applicant

Agent

London Legacy Development Corporation

Savills
Lansdowne House
57 Berkeley Square
London
W1J 6ER

DRAFT

Part I - Particulars of Application

Date of Application: 1 August 2012

Application No: 12/00066/FUM

Proposal: Full planning application for the transformation of the 2012 Olympic Stadium to provide a 60,000 seat multi-purpose venue with the capability of hosting top class athletics and football. The venue will have the facilities to enable it to be used for a wide range of sporting, cultural and community events, with a maximum capacity for concert events of 80,000 people, together with a community track and clubhouse, ancillary two storey concessionaire building, associated infrastructure, landscaping and retained bridges.

Location: Olympic Stadium Site PDZ3 Olympic Park London

Part II - Particulars of Decision

In pursuance of the powers under the above Act and Order the London Legacy Development Corporation hereby gives notice that **PLANNING PERMISSION HAS BEEN APPROVED** for the carrying out of the development referred to in Part I hereof and as described and shown on the application and plan(s) submitted, subject to the following condition(s) and notes:

Definitions

"1990 Act" means the Town and Country Planning Act 1990.

"BAP Habitat" means the type and quality of space and features to support the priority habitats and species outlined in the Olympic Park Biodiversity Action Plan 2008 (as shall be amended and/or replaced pursuant to the requirements of the Section 106 Agreement dated 28 September 2012 and made between (1) the Olympic Delivery Authority (2) the London Legacy Development Corporation and (3) Transport for London).

"Commencement" means the carrying out of a material operation as defined in section 56(4) of the 1990 Act excluding in this case the following: works to remove the existing seating at the Stadium; works to remove the existing field of play at the Stadium; works to remove the existing roof of the Stadium; and other deconstruction and decommissioning works at the Stadium and "Commence" and "Commenced" shall be construed accordingly.

"CRT Section 73 Permissions" means the following planning permissions:

- 11/90313/VARODA (variation of conditions OD.0.21 and LTD.1.3 of planning permission 07/90010/OUMODA);
- 11/90314/VARODA (variation of condition 43 of Olympic Consent Slot In Permission reference 08/90059/OUTODA);
- 11/90315/VARODA (variation of conditions VOD.15 and VLT.04 of Olympic Consent Slot In Permission reference 08/90276/FUMODA);
- 11/90316/VARODA (variation of condition PPR.21 of Olympic Consent Slot In Permission reference 08/90310/FULODA);
- 11/90317/VARODA (variation of condition PPR.21 of Olympic Consent Slot In Permission reference 08/90311/FULODA);
- 11/90318/VARODA (variation of condition PPR. 18 of Olympic Consent Slot In Permission reference 08/90312/FULODA);
- 11/90319/VARODA (variation of condition PPR.18 of Olympic Consent Slot In Permission reference 08/90313/FULODA);
- 11/90320/VARODA (variation of conditions HOD.12 and HLT.4 of Olympic Consent Slot In Permission reference 08/90328/FUMODA);
- 11/90321/VARODA (variation of conditions EMOD. 13 and EMLTD.7 of Olympic Consent Slot In Permission reference 09/90198/FUMODA);
- 11/90322/VARODA (variation of condition PGT.14 of Olympic Consent Slot In Permission reference 09/90410/FUMODA); and
- 11/90324/VARODA (variation of condition PPR.18 of Olympic Consent Slot In Permission reference 08/90314/FULODA).

"Development" means the development authorised by this permission and set out in Part 1 of this permission.

"Discharge of Remediation Conditions Protocol" means the protocol at Annexure 6 of the planning permission for the Legacy Communities Scheme Development.

"Draft Code of Construction Practice" means the document of the same name submitted in support of the planning application for the Development.

"Draft Global Remediation Strategy" means the Revised Global Remediation Strategy dated February 2012 which was submitted in support of the planning application for the Legacy Communities Development.

“Environmental Statement” means the environmental statement submitted in support of the planning application for the Development and the further environmental information submitted on 19 March 2013.

“Event” means a music concert or other cultural or leisure event with a capacity of up to 80,000 spectators.

“Event Day” means any day during which the Stadium is used to hold an Event.

“Event Management Coordination Framework” means the document approved pursuant to conditions LTD.26 of the Olympic Consents and LCS0.249 of the Legacy Communities Scheme Development.

“Framework Event Management Plan” means the document of the same name submitted in support of the planning application for the Development.

“GAC” means the Generic Assessment Criteria set out in the Draft Global remediation Strategy but to be updated so as to be based on:

- the most current guidance and legislation as exists at the date each Site Specific Remediation Strategy is prepared;
- the land uses proposed; and
- any additional contaminants of concern that have been identified.

“Global Conceptual Site Model” means the remediation works undertaken, validated and approved and the land uses adopted under the Olympic Consents.

“GWAC” means the Generic Water assessment Criteria set out in the Draft Global Remediation Strategy but to be updated so as to be based on:

- the most current guidance and legislation as exists at the date each Site Specific Remediation Strategy is prepared;
- the land uses proposed; and
- any additional contaminants of concern that have been identified.

“Legacy Communities Scheme Development” means the development approved under planning permission ref 11/90621/OUTODA and “LCS” shall be construed accordingly.

“Legacy Transformation Phase” means the phase of development permitted under the Olympic Consents which is between the closing ceremony of the 2012 Olympic and Paralympic Games and the 31st December 2014.

“Non Event Day” means a day during which the Stadium is not being used to hold an Event.

“Non Sports Event Day” means a day during which the Stadium is not being used to hold a Sports Event.

“North Park” means the area of parklands in the north of the Olympic Park as identified on the drawing at Annexure 3.

“Off Site” means outside of the Site.

“On Site” means within the Site.

"Operation" means both the day to day occupation and use of the Development and occupation and use for, and in connection with, Events and Sports Events but excludes occupation and use of the Development for the hosting of the Rugby World Cup 2015 programme and use and operation of the Development for the hosting of any other test events between 01 August 2015 and 31 October 2015 which have been agreed in writing in advance by the Local Planning Authority. "Operated" shall be construed accordingly.

"Olympic Consents" means:

- planning permission 07/90011/FUMODA;
- outline planning permission 07/90010/OUMODA;
- the CRT Section 73 Permissions; and
- planning permission 11/90330/FULODA

together with any Olympic Consent Slot In Permission (but excluding any Olympic Consent Slot In Permissions which are an approval of reserved matters).

"Olympic Consent Slot In Permission" means either a planning permission granted pursuant to an application to carry out development within the Olympic Park related to or in substitution for development authorised under:

- planning permission 07/90011/FUMODA;
- outline planning permission 07/90010/OUTODA;
- the CRT Section 73 Permissions;
- planning permission 11/90330/FULODA; and/or
- any planning permission that may be granted authorising the modification deletion or replacement of any condition attached to any Olympic Consent.

"Olympic Park" means the area edged red on the plan attached to this permission at Annexure 2

"Olympic Park Environmental Forum" means the forum to be convened by the environmental manager pursuant to condition LCS0.55 of the Legacy Communities Scheme Development planning permission.

"Olympic Park Remediation Forum" means the forum to be convened by the environmental manager pursuant to condition LCS0.55 of the Legacy Communities Scheme Development planning permission.

"Planning Delivery Zone" or **"PDZ"** means any one of the planning delivery zones established for the Olympic Consents.

"Planning Delivery Zone 3" means the area defined on the drawing attached to this permission at Annexure 2.

"Protection Layer" means the separation and marker layer of clean material placed across the site affected by the Olympic Consents.

"Publicly Accessible Open Space" means areas of coherent open space which are accessible to members of the public (and which may include areas where access is controlled) and which areas of open space include hard and soft landscaping but excludes the footprint of any building that is not ancillary to the enjoyment of that open space.

"Quality Review Panel" means either the LLDC Quality Review Panel or, in the event the LLDC Quality Review Panel is disbanded or suspended, the panel to be established pursuant to Condition LCS0.15 of the Legacy Communities Scheme Development planning permission to fulfil substantially the same purposes in respect of the Site.

“Remediation Change Note” means a document submitted to the Local Planning Authority detailing any unexpected contamination found and arrangements for its remediation.

“Remediation Works” means any works including an enabling works or carrying out of any operations or the taking of any steps for the purpose of treating preventing minimising remedying mitigating or monitoring the effects of any harm to the environment caused by the contamination of land or groundwater or any pollution of controlled waters so as to render the land in questions suitable for its intended end use and includes any installation of any works to prevent the movement of contaminants and the placing of clean soil or fill and any measures and controls to protect the integrity of existing remediation works carried out under the Olympic Consents.

“Resident Football Team” means the football team(s) whose home ground is the Stadium.

“Rugby World Cup 2015” means the international sporting event known as the Rugby World Cup to be hosted in England in September and October 2015.

“Rugby World Cup Events” means the use of the Development for the hosting of any Rugby World Cup 2015 rugby matches and the hosting of any ancillary events forming part of the Rugby World Cup 2015 programme; and use of the Development for the hosting of any other test events between 01 August 2015 and 31 October 2015 which have been agreed in writing in advance by the Local Planning Authority.

“Site” means the whole of the site enclosed within the 'red line' on Plan LC201-STA-STA-T-DGA-001 P01

“South Lawn” means the area of the Olympic Park as identified on the drawing attached to this permission at Annexure 3.

“Sports Event” means any of the following:

1. A Resident Football Team football match with a capacity of up to 54,000 spectators;
2. Any sports event (either pitch sports including athletics or non-pitch sports), which is not a Resident Football Team match, with a capacity of up to 60,000 spectators or a Resident Football Team match with a capacity of more than 54,000 spectators;
3. A World Championship Athletics Event with a capacity of up to 59,000 spectators.

“Sports Events Day” means any day during which the Stadium is to hold a Sports Event.

“Sustainability Statement” means the document of the same name submitted to support the planning application for the Development.

“Stadium” means the Olympic Stadium which is located within the Site.

“Validation Report” means documents prepared at the completion of the Remediation Works, the content of which and the process for approval is as described in the Discharge of Remediation Conditions Protocol.

“World Championship Athletics Event” means the event known as the World Championship in athletics organised by the International Association of Athletics Federations

List of Annexures:

1. Environmental Statement Table of Mitigation Measures.
2. Olympic Park, PDZ3 drawing
3. North Park and South Lawn area drawing
4. Noise management plan scope

DRAF

T

Conditions:

Time limits/compliance

- OST.1 The Development shall be Commenced before the expiration of three years from the date of this permission.

Reason: In accordance with section 91 of the Town and Country Planning Act 1990.

Approvals in Writing

- OST.2 Any application or submission for any other approval pursuant to the conditions of this planning permission shall be made in writing to the Local Planning Authority.

Reason: To ensure that a proper record is kept.

Works in accordance with approvals

- OST.3 Unless otherwise expressed in a condition, all details approved pursuant to conditions shall be implemented in full prior to the Operation of the Development.

Reason: To ensure that all works are properly implemented prior to the Operation of the development.

- OST.4 Unless minor variations are agreed by the Local Planning Authority and to the extent that such minor variation do not deviate from this permission, the Development shall be carried out in accordance with the following drawing numbers:

- LC201-STA-STA-T-DGA-0001 P01
- LC201-STA-GND-T-DSP-1501 P08
- LC201-STA-P00-T-DSP-1502 P07
- LC201-STA-GND-T-DGA-1510 P09
- LC201-STA-P00-T-DGA-1511 P08
- LC201-STA-P01-T-DGA-1512 P07
- LC201-STA-P02-T-DGA-1513 P07
- LC201-STA-P03-T-DGA-1514 P06
- LC201-STA-ROF-T-DGA-1516 P06
- LC201-STA-GND-T-DGA-1517 P09
- LC201-STA-P00-T-DGA-1521 P02
- LC201-STA-XXX-T-DGA-1530 P04
- LC201-STA-XXX-T-DGA-1531 P02
- LC201-STA-SCN-T-DSE-1572 P02
- LC201-STA-SCN-T-DSE-1573 P02
- LC201-STA-SCN-T-DSE-1574 P02
- LC201-STA-SCN-T-DSE-1575 P02
- LC201-STA-SCN-T-DSE-1580 P05
- LC201-STA-SCN-T-DSE-1581 P08
- LC201-STA-SCN-T-DSE-1582 P07
- LC201-STA-SCN-T-DSE-1583 P06
- LC201-STA-SCN-T-DSE-1584 P07
- LC201-STA-SCN-T-DSE-1585 P06
- LC201-STA-ELE-T-DEL-1594 P02
- LC201-STA-ELE-T-DEL-1595 P08
- LC201-STA-ELE-T-DEL-1596 P07
- LC201-STA-ELE-T-DEL-1597 P02

- LC201-STA-ELE-T-DEL-1598 P02
- LC201-STA-ELE-T-DEL-1599 P02
- LC201-STA-H04-CB-DGA-040 P03
- LC201-STA-H04-CB-DGA-0402 P01
- LC201-STA-H04-CB-DGA-0403 P01
- LC201-STA-F07-CB-DGA-0701 P02
- LC201-STA-F07-CB-DGA-0702 P01
- LC201-STA-F07-CB-DGA-0703 P01
- LC201-STA-F11-CB-DGA-1101 P03
- LC201-STA-F11-CB-DGA-1102 P02
- LC201-STA-F11-CB-DGA-1103 P01
- LC201-STA-F17-CB-DGA-1701 P03
- LC201-STA-F17-CB-DGA-1702 P01
- LC201-STA-F17-CB-DGA-1703 P01
- LC201-STA-WLD-T-DGA-1001 P02
- LC201-STA-WLD-T-DGA-1002 P02
- LC201-STA-WLD-T-DGA-1003 P01
- LC201-STA-WLD-T-DGA-1004 P02
- LC201-STA-WLD-T-DGA-1005 P01
- LC201-STA-WLD-T-DGA-1006 P02
- LC201-STA-WLD-T-REP-1001 P02
- LC201-STA-LAN-T-DGA-1001 P03
- LC201-STA-LAN-T-DGA-1003 P03
- LC201-STA-LHD-T-DGA-1001 P03
- LC201-STA-LHD-T-DGA-1002 P03
- LC201-STA-LHD-T-DGA-1003 P03
- LC201-STA-LHD-T-DGA-1004 P03
- LC201-STA-LHD-T-DGA-1005 P03
- LC201-STA-LHD-T-DGA-1006 P03
- LC201-STA-LHD-T-DGA-1007 P03
- LC201-STA-LHD-T-DGA-1008 P04
- LC201-STA-LHD-T-DGA-1009 P02
- LC201-STA-LAN-T-DGA-1102 P02
- LC201-STA-LAN-T-DSE-1001 P02
- LC201-STA-LAN-T-DSE-1002 P02
- LC201-STA-LAN-T-DSE-1003 P01
- LC201-STA-LHD-T-DMC-1001 P02
- LC201-STA-LHD-T-DMC-1002 P02
- LC201-STA-LHD-T-DMC-1003 P02
- LC201-STA-LHD-T-DMC-1004 P02
- LC201-STA-LSF-T-DMC-1001 P02
- LC201-STA-LSF-T-DMC-1002 P02
- LC201-STA-LSF-T-DMC-1003 P02
- LC201-STA-LAN-T-DDE-1000 P03
- LC201-STA-LAN-T-DDE-1002 P02
- LC201-STA-LAN-T-DDE-1003 P02
- LC201-STA-LAN-T-DDE-1004 P02
- LC201-STA-LAN-T-DDE-1009 P01
- LC201-STA-LAN-T-DDE-1010 P01

DRAFT

- LC201-STA-LAN-T-DGA-1200 P01
- LC201-STA-LSF-T-DGA-1201 P02
- LC201-STA-LSF-T-DGA-1202 P02
- LC201-STA-LSF-T-DGA-1203 P02
- LC201-STA-LSF-T-DGA-1205 P02
- LC201-STA-LSF-T-DGA-1206 P02
- LC201-STA-LSF-T-DGA-1207 P02
- LC201-STA-LSF-T-DGA-1208 P03
- LC201-STA-LAN-T-DGA-1210 P01
- LC201-STA-LSF-T-DGA-1213 P02
- LC201-STA-LSF-T-DGA-1215 P02
- LC201-STA-LSF-T-DGA-1216 P02
- LC201-STA-LSF-T-DGA-1217 P02
- LC201-STA-LSF-T-DGA-1218 P03
- LC201-STA-LSF-T-DGA-1219 P01
- LC201-STA-LAN-T-DGA-1220 P01
- LC201-STA-LAN-T-DGA-1230 P01
- LC201-STA-LAN-T-DGA-1231 P02
- LC201-STA-LAN-T-DGA-1232 P02
- LC201-STA-LAN-T-DGA-1233 P02
- LC201-STA-LAN-T-DGA-1235 P02
- LC201-STA-LAN-T-DGA-1236 P02
- LC201-STA-LAN-T-DGA-1237 P02
- LC201-STA-LAN-T-DGA-1238 P03
- LC201-STA-LAN-T-DGA-1239 P01
- LC201-STA-LAN-T-DDE-1230 P01
- LC201-STA-IRR-T-DGA-1000 P01
- LC201-STA-IRR-T-DGA-1001 P02
- LC201-STA-IRR-T-DGA-1002 P02
- LC201-STA-IRR-T-DGA-1003 P02
- LC201-STA-IRR-T-DGA-1005 P02
- LC201-STA-IRR-T-DGA-1006 P02
- LC201-STA-IRR-T-DGA-1007 P02
- LC201-STA-IRR-T-DGA-1008 P03

and the description of development contained in the application and any other plans, drawings, documents, details, schemes or strategies which have been approved by the Local Planning Authority pursuant to these conditions. All works shall be retained in accordance with the approved details.

Reason: To ensure that all works are properly implemented.

Notice of Commencement

OST.5

The Development shall not be Commenced until written notice of intention to Commence the Development has been given to the Local Planning Authority. The notice required by this condition shall only be given where there is a genuine prospect of Development being commenced within 21 days of the notice and the notice shall confirm and provide evidence that this is the case.

Reason: To ensure satisfactory compliance with this planning permission.

Development in accordance with the Environmental Statement

- OST.6 The Development shall be constructed and Operated in accordance with the mitigation measures set out in Annexure 1 unless otherwise provided for in any of these conditions or subject to any alternative mitigation measures as may be approved in writing by the Local Planning Authority, provided that such measures do not lead to there being any significant environmental effects other than those assessed in the Environmental Statement.

Reason: To ensure the mitigation measures specified in the Environmental Statement are satisfactorily implemented.

Design Details

Lighting strategy and details

- OST.7 The Development shall not be operated until an addendum lighting strategy to that previously approved for the Stadium under reference 08/90345/AODODA has been submitted to and approved by the Local Planning Authority. The addendum lighting strategy shall confirm which elements of existing lighting are retained and how any new lighting, both for architectural lighting and lighting to be installed in the public realm is consistent with the existing lighting that is to be retained and how such new lighting accords with the previously approved lighting strategy under reference 08/90345/AODODA.

No new external lighting or illumination, including sports lighting, shall be installed within the Development until details of the position, design, light outputs and lux levels, spread, hours of operation and a statement of compliance with the addendum lighting strategy have been submitted to and approved by the Local Planning Authority.

Reason: To ensure high standards of urban design and the protection of habitats and in order to minimise light pollution in accordance with policies 7.5, 7.19 and 7.30 of the London Plan and LB Newham Core Strategy policies SC4 and INF7 and saved policy EQ45.

Restriction on lighting

- OST.8 No lighting shall be installed beneath the retained bridges and along the towpaths within the Site without the prior written approval of the Local Planning Authority.

Reason: To ensure the protection of habitats in accordance with London Plan policies 7.19 and 7.30 and LB Newham Core Strategy policies SC4 and INF7 and LB Tower Hamlets Core Strategy policy SO19.

Wayfinding and Signage Strategy

- OST.9 The Development shall not be Operated until a Stadium wayfinding and signage strategy has been submitted to and approved by the Local Planning Authority. The strategy shall set out the design and operational principles for all wayfinding and signage to support public access to, from and within the Site, including crowd management before, during and after Events and Sports Events at the Site.

No external wayfinding structures and signage shall be installed until details of their position, design, illumination (including a statement of compliance with the lighting strategy) and external finish materials have been submitted to and approved by the Local Planning Authority.

Reason: To ensure that high standards of design are achieved in accordance with London Plan policy 7.6 and LB Newham Core Strategy policy SP3 and to assist with mitigating the impact of crowd movement.

External Materials

OST.10 Prior to the Commencement of the relevant part of the Development, samples of the external materials to be used for the following elements:

- Stadium roof;
- west stand extension;
- the void area between the rear of the retractable seating units and the podium; and
- community track clubhouse and spectator seating stand;

Shall be made available to the Local Planning Authority, either by way of a sample panel for inspection on Site or as materials submitted to the Local Planning Authority for approval. The samples shall show the colour, texture and finish of all external materials.

Reason: To ensure high standards of design are achieved in accordance with London Plan policy 7.6 and LB Newham Core Strategy policy SP3.

OST.11 Prior to the Commencement of any public realm and landscape works within the Site, full details, including drawings at a scale to be agreed in advance with the Local Planning Authority, and samples of the external materials to be used on all fences, walls and other means of enclosure within the Development, including balustrades at the Stadium podium and on the bridges and the fencing to enclose the community athletics track, shall be submitted to and approved by the Local Planning Authority.

Reason: To ensure high standards of design are achieved in accordance with London Plan policy 7.6 and LB Newham Core Strategy policy SP3.

Southern Lifts and Stairs

OST.12 Prior to the Commencement of construction works for the podium external lifts and stairs, full details of the design and appearance of these elements shall be submitted to and approved by the Local Planning Authority. The details submitted shall include drawings at a scale to be agreed in advance with the Local Planning Authority of the location, plan form, elevation and section of the lift and stairs and samples of the external finishes to be used, which shall show the colour, texture and finish of all external materials.

Reason: To ensure high standards of design are achieved in accordance with London Plan policy 7.6 and LB Newham Core Strategy policy SP3.

Sustainable Materials

OST.13 Not less than 20% of construction materials, by value, used in the Development shall be from a re-used, recycled or certified/accredited sustainable source.

Reason: To ensure that high standards of sustainability are achieved in accordance with London Plan policies 5.2 and 5.19 and LB Newham Core Strategy SC1 and INF3.

OST.14 Not less than 25% of aggregate by weight used in the permanent works forming part of the Development shall be from a recycled source.

Reason: To ensure that high standards of sustainability are achieved in accordance with London Plan policies 5.2 and 5.19 and LB Newham Core Strategy policy SC1 and INF3.

Stadium Spectator Facilities Buildings and Structures

- OST.15 Notwithstanding the details shown on the drawings hereby approved the location and detailed design and appearance of the stadium spectator facilities buildings and gate-line structures including the means of enclosure between the stadium and the gate-line are not approved as part of this permission. Details of the location and detailed design and appearance of these buildings and gate-line structures, including the means of enclosure between the Stadium and the gate-line shall be submitted to and approved by the Local Planning Authority prior to the Commencement of the Development.

Reason: To ensure a high standard of design and appearance for this important element of the stadium building in accordance with policies London Plan policy 7.6 and LB Newham Core Strategy policy SP3.

- OST.16 No application pursuant to condition 15 (Stadium Spectator Facilities Buildings and Structures) shall be submitted to the Local Planning Authority for approval until the detail has first been submitted to the Quality Review Panel for consultation.

Reason: To ensure a high standard of design and appearance for this important element of the stadium building in accordance with London Plan policy 7.6 and LB Newham Core Strategy policy SP3.

Concessionaire Building

- OST.17 Notwithstanding the details shown on the drawings hereby approved prior to the Commencement of the Development, full details of the design and external appearance of the concessionaire building shall be submitted to and approved by the Local Planning Authority. The details submitted shall include drawings at a scale to be agreed in advance with the Local Planning Authority of the plan form, elevation and section of the building.

Reason: To ensure that high standards of design are achieved in accordance with London Plan policy 7.6 and LB Newham Core Strategy policy SP3.

Access and Inclusion

- OST.18 Prior to the Operation of the Development confirmation of the total provision for wheelchair accessible seating and accessible seating in both Sports Event and Events modes shall be submitted to and approved by the Local Planning Authority. Provision shall be no less than that shown on the drawings hereby approved.

Reason: To ensure that high standards of accessible design are achieved in accordance with London Plan policy 7.2 and LB Newham Core Strategy policy SP3.

Stadium Signage

- OST.19 Notwithstanding the provisions of the Town and Country Planning (Control of Advertisements) Regulations 2007, no advertisements or signs, other than temporary directional signs, shall be erected on the exterior structure of the Stadium or images projected on to the external structure of the Stadium without the prior written approval of the Local Planning Authority.

Reason: To provide control over the size and design of signage and advertisements given the particular character and appearance of the stadium and Olympic Park area, to protect local amenity and the wellbeing of the area and to ensure the maintenance of design quality in accordance with London Plan policy 7.6 and LB Newham Core Strategy policy SP3.

Landscaping

OST.20 The landscaping of the Development shall be undertaken in accordance with the details shown in the approved drawings, except with respect to the following:

- Pedestrian crossover at community track access road;
- Pedestrian crossover at the southern loop road.

The details, of these elements are to be submitted to and approved by the Local Planning Authority prior to the Commencement of landscape and public realm works within the Development.

Reason: To ensure that high standards of landscape design are achieved in accordance with London Plan policies 7.5 and 7.21 and LB Newham Core Strategy policy SP3 and saved policy EQ15.

Replacement of trees and shrubs

OST.21 Any retained tree or any tree or shrub planted as part of any landscaping provided within the Development that, within a period of five years from the date of planting, is removed, dies or becomes seriously damaged or diseased, shall be replaced in the next planting season with a specimen of an appropriate size and the same species as originally present or planted in the next available planting season, unless otherwise agreed by the Local Planning Authority.

Reason: To ensure that trees and landscaping are properly maintained to ensure that high standards of landscape quality are achieved in accordance with London Plan policies 7.5 and 7.21 and LB Newham Core Strategy policy SP3 and saved policy EQ15.

Management and Maintenance

OST.22 The Development shall not be operated until the management and maintenance details for all public realm, publicly accessible open space and BAP Habitat within the Site has been submitted to and approved by the Local Planning Authority. The details submitted shall take into account and as necessary dovetail with the Local Planning Authority approved management and maintenance strategy and details for the Olympic Park. All areas of public realm, publicly accessible open space and BAP Habitat shall thereafter be managed and maintained in accordance with the details so approved.

Reason: To ensure an appropriate management and maintenance regime is in place for the public realm, areas of publicly accessible open space and BAP Habitat and to dovetail with those details approved for the Olympic Park in accordance with London Plan policy 7.19 and LB Newham Core Strategy policy SC4.

Security Measures

OST.23 The Development shall not be operated until details of hostile vehicle mitigation, CCTV and other security infrastructure details within the Site have been submitted to and approved by the Local Planning Authority. The details submitted shall include a statement of how the measures proposed are in accordance with any approved security strategy or frameworks for the Olympic Park.

Reason: To ensure that appropriate security measures are in place to mitigate the impact of the development and to ensure high standards of design in accordance with London Plan policies 7.3, 7.5, 7.6 and 7.13 and LB Newham Core Strategy policy SP3 and to dovetail with those details approved for the Olympic Park.

Community Athletics Track

- OST.24 Prior to the Operation of the Development full details of the specification and surface finish, including colour, of the community athletics track shall be submitted to and approved by the Local Planning Authority. The specification of the community athletics track shall be in accordance with the International Association of Athletics Federations Category 1 accreditation required for the Stadium.

Reason: To ensure an appropriate standard of community athletics track is provided and to ensure a high standard of design in accordance with London Plan policies 3.19, 7.5 and 7.6 and LB Newham Core Strategy policy SP3.

Drainage Details

- OST.25 Prior to the Commencement of any permanent drainage infrastructure forming part of the Development details of the surface water drainage scheme proposed to be installed at the Site shall be submitted to and approved by the Local Planning Authority. The details submitted shall include an assessment of the hydrological and hydrogeological context of the Development and details of the critical storm events that exceed the capacity of the proposed drainage system. The scheme shall provide full details of how the surface water drainage will be managed to protect water quality of the City Mill River and Old River Lee, including the assessment of potential pollution impacts from the surface water drainage of areas of car parking and vehicle washing and drainage from waste storage and bulking areas. Details to be submitted shall also include pollution prevention measures and the use of Sustainable Urban Drainage Systems as appropriate.

No infiltration of surface water drainage into the ground is permitted other than with the express written consent of the Local Planning Authority, which may be given for those parts of the Site where it has been demonstrated that there is no resultant unacceptable risk to controlled waters. The Development shall be carried out in accordance with the details set out in any such express written consent.

Reason: To provide for sufficient drainage of the development and to protect controlled waters from contamination in accordance with London Plan policies 5.13 and 5.21 and LB Newham saved policy EQ49

Bridge design details

- OST.26 Details of all external finishes to be used on the temporary bridges hereby approved to be retained shall match those used on the permanent bridges with respect to colour, texture and detailing of external materials including the gabions to the bridge abutments; the painting of the bridge structure; surface treatment to the bridge decks; balustrades and handrails.

Reason: To ensure a consistent and high standard of design and appearance in accordance with London Plan policy 7.6, LB Newham Core Strategy policy SP3 and LB Tower Hamlets Core Strategy policy SO19.

- OST.27 A sample of the new bespoke benches which are to enclose the interface between the temporary bridges hereby approved to be retained and the permanent bridges, shall be submitted and approved by the Local Planning Authority prior to their construction/installation. All other benches and seating proposed to be installed on the bridges shall be of a design to match that used for benches and seating elsewhere in the Olympic Park public realm.

Reason: To ensure a consistent and high standard of design and appearance in accordance with London Plan policies 7.5 and 7.6 and LB Newham Core Strategy policy SP3 and LB Tower Hamlets Core Strategy policy SO19.

- OST.28 Prior to the Operation of the Development, full details of the number and location of bird and bat boxes to be provided within the structure of the bridges shall be submitted to and approved by the Local Planning Authority.

Reason: To mitigate the biodiversity impact of the development and to ensure a high standard of design and appearance in accordance with London Plan policies 7.19 and 7.30 and LB Newham Core Strategy policies SC4 and INF7 and LB Tower Hamlets Core Strategy policy SO19.

Land Use

Retail floorspace

- OST.29 The amount of retail floorspace in the Development shall not exceed 3538 sq.m and shall be strictly ancillary to the use of the Stadium and for no other purpose without the prior written approval of the Local Planning Authority.

Reason: To ensure the Development is carried out in accordance with the approved plans and other submitted details and to ensure that the amount of floorspace keeps within the parameters assessed pursuant to the Environmental Statement in relation to the Development.

Community Athletics and Sports facilities

- OST.30 The community athletics track and sports facilities hereby approved shall be implemented by 1 May 2017 and made available for use by 1 September 2017. There shall be no Operation of the Stadium for any purpose after 1 September 2017 unless the community athletics track has been provided and is available for use.

Reason: To ensure that suitable provision is made for community sports provision in accordance with policies 2.4, 3.19 and 4.6 in the London Plan and LBN Core Strategy policy SO3, INF8 and SP2.

- OST.31 The athletics track and sports facilities hereby approved shall be for community sports use only unless required in connection with an Event or Sports Event in the Stadium as agreed through the prior approval by the Local Planning Authority of the event management plan for that Event or Sports Event.

Reason: To ensure that suitable provision is made for community sports provision in accordance with policies at 2.4, 3.19 and 4.6 in the London Plan and LBN Core Strategy policy SO3, INF8 and SP2.

- OST.32 The community athletics and sports clubhouse and spectator stand hereby approved shall be constructed and made available for use prior 1st September 2017. There shall be no Operation of the Stadium for any purpose after 1st September 2017 unless the community athletics and sports clubhouse and spectator stand has been provided and is available for use.

Reason: To ensure that suitable provision is made for community sports provision in accordance with the policies 2.4, 3.19 and 4.6 in the London Plan and LBN Core Strategy policy SO3, INF8 and SP2.

Stadium Use and Capacity

OST.33 The Stadium shall operate to a maximum capacity of 60,000 spectators for Sports Events use. The use of the Stadium for Sports Events shall not exceed 87 days per calendar year.

Reason: To ensure the Development is operated in accordance with the approved details and within the parameters assessed pursuant to the Environmental Statement.

OST.34 The Stadium shall operate to a maximum capacity of 80,000 spectators for Events use.

Reason: To ensure that the Development is operated in accordance with the approved details and within the parameters assessed pursuant to the Environmental Statement.

OST.35 No Events or Sports Events shall be held at the Stadium which have a music noise level in excess of 75 dB(A) 15 mins Leq measured 1m from the facade of sensitive receptors.

Reason: To ensure the Development is operated in accordance with the approved details and within the parameters assessed pursuant to the Environmental Statement and to safeguard the amenities of sensitive receptors from the use of the stadium in accordance with London Plan policy 7.15 and LB Newham saved policies EQ45 and EQ48

OST.36 No more than 10 Events shall be held at the Stadium per calendar year of which:

- 6 are permitted to have a music noise level of not more than 75dB(A) 15mins Leq measured 1m from the facade of sensitive receptors; and
- 4 are permitted to have a music level of not more than 65dB(A) 15 mins Leq measured 1m from the facade of sensitive receptors.

Reason: To ensure the Development is operated in accordance with the approved details and within the parameters assessed pursuant to the Environmental Statement and to safeguard the amenities of sensitive receptors from the use of the stadium in accordance with London Plan policy 7.15 and LB Newham saved policies EQ45 and EQ48.

OST.37 No more than three Events with a music noise level of not more than 75 dB(A) 15mins Leq measured 1m from the facade of sensitive receptors shall be held on consecutive days at the Stadium. There shall be a minimum of three days without Events in the Stadium between a programmed period of Events on three consecutive days.

Reason: To ensure that the Development is operated within the parameters assessed pursuant to the Environmental Statement and to safeguard the amenities of sensitive receptors from the use of the stadium in accordance with London Plan policy 7.15 and LB Newham saved policies EQ45 and EQ48.

OST.38 There shall be no Events held within the Stadium on the same day as an Event is held on the South Lawn and/or in the North Park of the Olympic Park as defined on the drawing at Annexure 3 to this permission unless where suitable mitigation is identified in an event management plan and/or noise management plan or in an update to an approved event management plan and/or noise management plan, which is submitted to and approved by the Local Planning Authority pursuant to conditions OST 106 and OST 111 of this permission or condition SL22 of the South Lawn planning permission reference 12/00227/OUT which is sufficient to enable Events in the Stadium and the South Lawn and/or North Park to be held on the same day.

Reason: To ensure that the Development is operated within the parameters assessed pursuant to the Environmental Statement and to safeguard the amenities of sensitive

receptors from the use of the stadium in accordance with London Plan policy 7.15 and LB Newham saved policies EQ45 and EQ48.

Bridges

OST.39 There shall be no Operation of the Development until all the works to bridges H04, F11, F07 and F17 hereby approved have been implemented and the bridges made available for public use.

Reason: In the interests of crowd movement, public access and to mitigate the impact of the development in accordance with London Plan policies 6.1 and 7.13 and LB Newham Core Strategy INF2 and LB Tower Hamlets Core Strategy Policy SO19.

DRAFT
T

Hours of Operation

- OST.40 The Operation of the Stadium for Sports Events shall take place only between the hours of 0800-2300 Monday to Saturday and 0800-2230 on Sunday.

Reason: To ensure the Development is operated in accordance with the approved details and within the parameters assessed pursuant to the Environmental Statement and to safeguard the amenities of sensitive receptors from the use of the stadium in accordance with London Plan policy 7.15 and LB Newham saved policies EQ45 and EQ48.

- OST.41 The Operation of the Stadium for Events shall take place only between the hours of 0900-2230 Monday to Sunday unless where suitable mitigation is identified in both an event management plan and noise management plan or in an update to an approved event management plan and/or noise management plan which is submitted to and approved by the Local Planning Authority pursuant to conditions OST 106 and OST 111 for an Events use, in which case the hours of operation would be limited to 0800-2300 Monday to Sunday.

Reason: To ensure that the Development is operated within the parameters assessed pursuant to the Environmental Statement and to safeguard the amenities of sensitive receptors from the use of the stadium and in accordance with London Plan policy 7.15 and LB Newham saved policies EQ45 and EQ48.

- OST.42 Outside of the hours of Operation for Sports Events and Events use of the Stadium set out in conditions OST 40 and OST 41 ancillary start-up and break down operating periods prior to and after each Event and Sports Event shall be set out in accordance with that approved in the event management plan and noise management plan for each Event and Sports Event as applicable.

Reason: To safeguard the amenities of sensitive receptors from the operation of the stadium in accordance with London Plan policy 7.15 and LB Newham saved policies EQ45 and EQ48.

Floodlight and Public Address system use

- OST.43 Other than for testing purposes, the field of play floodlights in the Stadium and public address system at the Stadium and the Stadium podium shall be limited to use for a period not exceeding two hours prior to the commencement of an Event or Sports Event, but in any case no earlier than 0800 Monday-Sunday. In the case of Events or Sports Events finishing at either 2230 or 2300 Monday-Sunday, the field of play floodlighting within the Stadium and public address system within the Stadium and on the Stadium podium shall not be used after midnight. Specific exceptions to this restriction for Events or Sports Events may be agreed by the Local Planning Authority subject to mitigation and other operating restrictions as set out in the relevant event management plan or noise management plan approved by the Local Planning Authority pursuant to conditions OST 106 and OST 111.

Reason: To safeguard the amenities of sensitive receptors from the operation of the stadium in accordance with London Plan policy 7.15 and LB Newham saved policies EQ45 and EQ48.

OST.44 The Operation of the concessionaire building, community athletics track and sports facilities, including sports lighting and public address systems, community sports clubhouse accommodation, car park and spectator stand shall be between the hours of 0700-2230 Monday-Sunday only and at no other time without the prior written approval of the Local Planning Authority.

Reason: To safeguard the amenities of sensitive receptors from the operation of the stadium in accordance with London Plan policy 7.15 and LB Newham saved policies EQ45 and EQ48.

Interim Uses

OST.45 None of the rights contained in Part 4 Class B of Schedule 2 of the Town and Country Planning (General Permitted Development Order) 1995 shall be exercised within the Site unless otherwise agreed with the Local Planning Authority as part of a written framework approved by the Local Planning Authority setting out thresholds for the temporary use of land in respect of which such rights shall be exercisable.

Reason: To provide control over potential temporary uses given the particular character and appearance of the stadium and Olympic Park area, to protect local amenity and the wellbeing of the area and to ensure the maintenance of design quality in accordance with London Plan policy 7.5 and 7.6 and LB Newham Core Strategy policy SP3.

Construction

Deconstruction and decommissioning works

OST.46 All works to remove the existing seating at the Stadium, remove the existing field of play and to remove the existing roof at the Stadium as well as other Stadium deconstruction and decommissioning works to be undertaken prior to the Commencement of the Development shall be carried out in accordance with the code of construction practice and subsidiary documents approved pursuant to condition LTD.14 and during the hours specified in LTD 1.7 of the Olympic Consents.

Reason: To ensure that all pre-Commencement works comply with the approved Olympic Park Code of Code of Construction Practice and subsidiary documents and safeguard the amenities of sensitive receptors in accordance with London Plan policies 7.14 and 7.15 and LB Newham saved policies EQ45 and EQ48.

Environmental Manager

OST.47 The Development shall not be commenced until an environmental manager has been appointed or nominated and evidence of the appointment or nomination provided to the Local Planning Authority. An environmental manager shall be retained or nominated at all times throughout the construction of the Development. The environmental manager shall be responsible for the following:

- Submitting environmental management plans to the Local Planning Authority;
- Monitoring and auditing compliance with commitments in the code of construction practice and with all relevant environmental legislation;
- Submitting annual compliance monitoring reports to the Local Planning Authority for approval.
- Attending the Olympic Park Environmental Forum for the reporting and discussion of noise and air quality monitoring in accordance with terms of reference to be agreed as part of the Site Wide code of construction practice;
- Attending the Olympic Park Remediation Forum for the reporting and discussion of contamination and remediation in accordance with terms of reference to be agreed as part of the code of construction practice.

Reason: To ensure that the construction and environmental mitigation measures are appropriately implemented in accordance with London Plan policies 7.14 and 7.15 and LB Newham saved policies EQ45 and EQ48.

Code of Construction Practice and subsidiary documents

OST.48 The Development shall not be commenced until a code of construction practice (CoCP), which shall be in accordance with the Draft Code of Construction Practice and all approved CoCP's for the Legacy Transformation Phase of the Olympic Consents and Legacy Communities Scheme Development, has been submitted to and approved by the Local Planning Authority. The code of construction practice shall include terms of reference for attendance of the environmental manager at the Olympic Park Environmental Forum and Olympic Park Remediation Forum. The code of construction practice shall be in accordance with all relevant legislation in force, and substantially in accordance with all policy adopted and best practice guidance published at the time of submission.

Reason: To ensure that the construction and environmental mitigation measures are appropriately implemented in accordance with London Plan policies 7.14 and 7.15 and LB Newham saved policies EQ45 and EQ48

OST.49 The Development shall not be commenced until a construction transport management plan (CTMP) has been submitted to and approved by the Local Planning Authority. The CTMP shall be prepared in consultation with the Local Planning Authority, local highway authorities, Transport for London and the emergency services, and shall be in accordance with the approved CTMPs for the Legacy Transformation Phase of the Olympic Consents and Legacy Communities Scheme Development. The objectives of the CTMP shall be to:

- minimise the level of road based construction traffic through the promotion of rail and water based transport options and where feasible the provision of facilities for the movement of construction materials by rail and water taking into account material loads suitable for movement by rail and water and logistical and other requirements (such as statutory consultee requirements);
- minimise the impact of road based construction traffic by identifying clear controls on routes for large goods vehicles, vehicle types, vehicle quality and hours of site operation;
- identify highway works required to accommodate construction traffic;

- minimise the number of private car trips to and from the Site (both workforce and visitors) by encouraging alternative modes of transport and identifying control mechanisms for car use and parking; and
- assess the need for improvements to the public transport network to accommodate the additional number of trips associated with construction site activity.

Reason: To ensure that the construction and environmental mitigation measures are appropriately implemented in accordance with London Plan policies 7.14 and 7.15 and LB Newham saved policies EQ45 and EQ48

OST.50

The Development shall not be commenced until a construction waste management plan (CWMP) has been submitted to and approved by the Local Planning Authority. The CWMP shall be in accordance with the approved CWMPs for the Legacy Transformation Phase of the Olympic Consents and Legacy Communities Scheme Development. The objectives of the CWMP shall be to ensure all waste arising from the Development construction works are managed in a sustainable manner, maximising the opportunities to reduce, reuse and recycle waste materials. The CWMP shall also detail the compliance and assurance requirements to be maintained on the Site during construction. The CWMP shall include as a minimum the following information:

- classification of all waste including hazardous waste according to current legislative provisions;
- performance measurement and target setting against estimated waste forecasts;
- reporting of project performance on quantities and options utilised;
- measures to minimise waste generation;
- opportunities for re-use or recycling;
- provision for the segregation of waste streams on the Site that are clearly labelled;
- licensing requirements for disposal sites;
- an appropriate audit trail encompassing waste disposal activities and waste consignment notes;
- measures to avoid fly tipping by others on lands being used for construction.
- returns policies for unwanted materials; and
- measures to provide adequate training and awareness through toolbox talks.

Reason: To ensure that the construction and environmental mitigation measures are appropriately implemented in accordance with London Plan policies 7.14 and 7.15 and LB Newham saved policies EQ45 and EQ48.

Demolition waste

OST.51 The Development shall not be Commenced until a demolition and site waste management strategy has been submitted to and approved by the Local Planning Authority. The demolition and site waste management strategy shall be in accordance with the code of construction practice and prepared in consultation with the Environment Agency. It shall contain as a minimum the following information:

- waste minimisation and recycling targets;
- waste forecast from the demolition activities and from the proposed buildings and infrastructure works;
- waste management options, waste minimisation opportunities and design for materials resource efficiency;
- opportunities to eliminate, reduce, reuse, recycle and recover materials;
- waste minimisation opportunities through design (design out waste), construction and lean operations;
- control processes and mitigation procedures for storing waste and transporting it off the Site;
- a site waste management plan (SWMP);
- details of the provision of facilities for On Site treatment of contaminated soils and stockpiling of material for use in later phases of the Development;
- details of facilities for On Site storage of construction and demolition wastes pending re-use, recycling or collection for management Off Site;
- a statement as to how all demolition work will be carried out substantially in accordance with the ICE Demolition Protocol, and the GLA/London Council's guidance on 'The Control of Dust and Emissions for Construction and Demolition' 2006; and
- a statement as to how assessments of the recycled content (by value) will be undertaken.

Reason: To minimise waste generated by the construction of the Development and ensure that high standards of sustainability are achieved.

OST.52 The Development shall comply with the commitments given by the applicant as a signatory to WRAP's Halving Waste to Landfill declaration.

Reason: To minimise the waste generated by the construction of the Development in accordance with London Plan policy 5.18 and LB Newham Core Strategy INF3.

Construction Works in accordance with Approved Documents

OST.53 The Development, including works of demolition, shall be undertaken in accordance with the following documents approved pursuant to the aforementioned Conditions:

- code of construction practice
- environmental management plans, topical environmental management plans, project environmental management plans, water management plans, ecology management plans and pollution incident control plans referred to in the code of construction practice;
- construction transport management plan;
- demolition and site waste management strategy;
- construction waste management plan.

Reason: To ensure that the construction and environmental mitigation measures are appropriately implemented in accordance with London Plan policies 7.14 and 7.15 and LB Newham saved policies EQ45 and EQ48.

Hours of Construction Work

- OST.54 There shall be no demolition or construction work outside the hours of 08.00 to 18.00 on Monday to Friday and 08.00 to 13.00 on Saturdays nor at any time on Sundays or on Bank or Public Holidays without the prior written approval of the Local Planning Authority. Construction work audible at the façade of any noise sensitive premises may only take place outside these permitted hours of work where these works have been approved by the Local Authority under section 61 of the Control of Pollution Act 1974.

Reason: To protect the amenities and environment of residents and other sensitive receptors in accordance with London Plan policies 7.14 and 7.15 and LB Newham saved policies EQ45 and EQ48.

Approval of On Site Construction Facilities

- OST.55 Details of existing Olympic Consents temporary facilities which are proposed to be retained for use in support of the construction of the Development shall be shown on a drawing to be submitted to and approved by the Local Planning Authority prior to the Commencement of the Development. Prior to the installation of any of the following new construction facilities on the Site, details of the siting and dimensions of that construction facility shall be submitted to and approved by the Local Planning Authority:

- prefabricated buildings greater than two storeys or a footprint of 200sqm within 100m of the boundary of the Site;
- concrete batching plant;
- temporary loading and unloading points at the waterside;
- waste sorting and despatch facilities; and
- parking areas for more than ten contractors' plant or vehicles within 100m of the Site boundary.

If, following approval, any of the facilities needs to be moved, the Local Planning Authority shall be given 14 days notice of any intended move. Unless the Local Planning Authority gives notice to the contrary within that period, the move can take place.

Reason: To protect the amenities of local residents and other sensitive receptors in accordance with London Plan policies 7.14 and 7.15 and LB Newham saved policies EQ45 and EQ48.

Construction Fence

- OST.56 The Development shall not be Commenced until details of any new or additional perimeter construction fencing to be erected, including its location, height, form of construction and the intended length of time it will remain in place, shall be submitted to and approved by the Local Planning Authority.

Reason: To ensure that the environmental or other impacts of the construction fencing are minimised in accordance with London Plan policies 7.14 and 7.15 and LB Newham saved policies EQ45 and EQ48

Construction delivery arrangements

- OST.57 All deliveries to the Site or removal of materials from the Site shall take place during the hours and in the manner specified in the construction transport management plan.

Reason: To ensure that the environmental or other impacts of the construction fencing are minimised in accordance with London Plan policies 7.14 and 7.15 and LB Newham saved policies EQ45 and EQ48

Construction Dust

OST.58 The Development shall not be Commenced until a scheme for dust monitoring, assessment and mitigation for all construction activities has been submitted to and approved by the Local Planning Authority. The scheme shall be in accordance with the best practice guidance entitled 'The control of dust and emissions from construction and demolition' published by the GLA in November 2006 and shall include:

- The identification of dust sensitive premises to be used as the location for dust monitoring, including any arrangements proposed for amending the selected locations if new dust sensitive premises are introduced;
- The frequency and other arrangements for dust monitoring; and
- The arrangements for reporting the results of dust monitoring and the implementation of mitigation measures to the Local Planning Authority.

Reason: To ensure that the environmental or other impacts of the construction fencing are minimised in accordance with London Plan policies 7.14 and 7.15 and LB Newham saved policies EQ45 and EQ48

Construction noise and vibration

OST.59 The Development shall not be Commenced until a scheme for noise monitoring, assessment and mitigation for all construction plant and processes has been submitted to and approved by the Local Planning Authority. The scheme shall include:

- The identification of noise sensitive premises to be used as the location for noise monitoring, including any arrangements proposed for amending the selected locations if new noise sensitive premises are introduced during the construction period;
- The noise parameters to be measured and the circumstances when continuous monitoring will be undertaken;
- The arrangements for reporting the results of noise monitoring to the Local Planning Authority;
- The arrangements for submitting applications for consent under section 61 of the Control of Pollution Act 1974; and
- The arrangements for implementing mitigation measures for sensitive premises during construction.

Reason: To ensure that the environmental or other impacts of the construction fencing are minimised in accordance with London Plan policies 7.14 and 7.15 and LB Newham saved policies EQ45 and EQ48

OST.60 Noise levels at any occupied residential property due to construction or demolition shall not exceed 75dB LAeq (10 hour) measured at 1m from the façade of the nearest occupied property, during the hours from 08:00 to 18.00 Monday-Friday, and shall not exceed 75dB LAeq (5 hour) during the hours from 08:00 to 13:00 on Saturday except with the prior approval of the Local Authority, under s61 of the Control of Pollution Act 1974.

Reason: To ensure that best practicable means are used to reduce noise generated by construction in accordance with London Plan policies 7.14 and 7.15 and LB Newham saved policies EQ45 and EQ48

OST.61 Noise from construction work shall give rise to noise levels no higher than 65dB LAeq (1 hour) and 70dB LAeq (1 minute) at any educational premises measured at 1m from the façade of the building during school hours in term time, except with the prior written approval of the Local Authority under section 61 of the Control of Pollution Act 1974.

Reason: To ensure that best practicable means are used to reduce noise generated by construction in accordance with London Plan policy 7.15 and LB Newham saved policies EQ45 and EQ48.

OST.62 No impact piling shall take place unless it has the prior written approval of the Local Planning Authority and takes place in accordance with the terms of any such approval, or in accordance with a consent issued under section 61 of the Control of Pollution Act, 1974.

Reason: To avoid, wherever possible, unnecessary noise from piling operations in accordance with London Plan policies 7.14 and 7.15 and LB Newham saved policies EQ45 and EQ48.

OST.63 The Development shall not be Commenced until a schedule of premises containing people or equipment potentially sensitive to disturbance from vibration or any buildings potentially at risk of damage from vibration (in each case caused by construction operations on the Site) has been submitted to and approved by the Local Planning Authority. This shall be accompanied by proposals for monitoring vibration levels, where necessary, ensuring that, as far as practicable, vibration levels do not exceed the thresholds set out in the approved code of construction practice and that appropriate mitigation or remedial measures are to be employed.

Reason: To ensure that best practicable means are used to avoid damage or nuisance from vibration during construction in accordance with London Plan policies 7.14 and 7.15 and LB Newham saved policies EQ45 and EQ48.

Sustainable Waste

OST.64 The construction of the Development shall achieve a 70% reduction in total construction, demolition and excavation waste sent to landfill by way of re-use, recycling and recovery.

Reason: To minimise waste generated by the construction of the Development and ensure that high standards of sustainability are achieved in accordance with London Plan policies 5.16 and 5.18 and LB Newham Core Strategy policy INF3.

OST.65 Not less than 90% of waste, by weight, arising from demolition works as part of the Development shall be re-used or recycled.

Reason: To minimise waste generated by the construction of the Development and ensure that high standards of sustainability are achieved in accordance with London Plan policies 5.16 and 5.18 and LB Newham Core Strategy policy INF3.

Removal of buildings and equipment on completion

OST.66 All plant, temporary buildings, structures, fencing and other construction equipment shall be removed prior to the Operation of the Development

Reason: To avoid unnecessary visual or other environmental impacts in accordance with London Plan policy 7.5 and LB Newham Core Strategy policy SP3..

Building height limits

OST.67 Without the prior written approval of the Local Planning Authority, no temporary or permanent building (including any crane, aerial or antenna) which exceeds the height of 154.95m AOD shall be erected in connection with the Development.

Reason: To ensure that operations at London City Airport are safeguarded.

Permitted Development

OST.68 Notwithstanding the provisions of Parts 4 and 5 of Schedule 2 of the Town and Country Planning (General Permitted Development) Order 1995, no part of the Site shall be used for the stationing of sleeping accommodation for site workers, unless the approval of the Local Planning Authority has first been obtained.

Reason: To provide control over use of the Site during construction given the particular character and appearance of the Olympic Park area and to protect local amenity and the wellbeing of the area in accordance with London Plan policy 7.5 and 7.6 and LB Newham Core Strategy policy SP3.

OST.69 Notwithstanding the provisions of Part 4 Class A of Schedule 2 of the Town and Country Planning (General Permitted Development) Order 1995, no land outside but adjoining the Site shall be used for the provision of temporary buildings, works, plant or construction machinery, unless the approval of the Local Planning Authority has first been obtained.

Reason: To provide control over the use of land adjoining the Site during construction given the particular character and appearance of the Olympic Park area and to protect local amenity and the wellbeing of the area in accordance with London Plan policy 7.5 and 7.6 and LB Newham Core Strategy policy SP3.

Contaminated Land and Remediation

Validation of Olympic Consents Remediation Works

OST.70 No Development works which affect or are below the existing contamination remediation marker layer shall be Commenced unless and until:

- validation of the remediation works as required by Conditions SP.0.32 to SP.0.36 of planning permission 07/90011/FUMODA and OD.0.36 to OD.0.38 and LTD.16 of planning permission 07/90010/OUMODA and 11/90313/VARODA which relate to the whole of Planning Delivery Zones 3 and those parts of 2 and 4 as they relate to bridges within the Site have been submitted to and approved by the Local Planning Authority;
- the consolidated validation reports for such remediation works for that relevant Planning Delivery Zone have been submitted, validated and approved by the Local Planning Authority; and
- there are no outstanding actions or ongoing requirements under Conditions SP.0.32 to SP.0.36 planning permission 07/90011/FUMODA and OD.0.36 to OD.0.38 and LTD.16 of planning permission 07/90010/OUMODA and 11/90313/VARODA in the relevant Planning Delivery Zone save for any ongoing monitoring required to enable the full discharge of those conditions.

Reason: To ensure that the remediation works required under the Olympic Consents and which are relevant to the Planning Delivery Zone are completed before Commencement of the Development in accordance with London Plan policy 5.21, LB Newham saved policy EQ49 and LB Tower Hamlets saved policy DEV.51.

Global Remediation Strategy

OST.71 No Development works which affect or are below the existing contamination remediation marker layer shall be commenced until a global remediation strategy, has been submitted to and approved by the Local Planning Authority.

Reason: To ensure that all Remediation Works are properly carried out in accordance with London Plan policy 5.21, LB Newham saved policy EQ49 and LB Tower Hamlets saved policy DEV.51.

Remediation Statement

OST.72 No Development works which affect or are below the existing contamination remediation marker layer shall be Commenced until a remediation statement for the Site has been submitted to and approved by the Local Planning Authority. The remediation statement shall include as a minimum the following:

- consideration of the consolidated validation reports for the Olympic Consents within the relevant Planning Delivery Zone for the Site(or such other area as may have agreed with the Local Planning Authority);
- consideration and confirmation of the measures and controls needed to maintain the integrity of the remediation works undertaken under the Olympic Consents within the relevant Planning Delivery Zone for the Site (or such other area as may have been agreed with the Local Planning Authority);
- an assessment of the Global Conceptual Site Model against the land uses proposed which should be read in conjunction with the approved global remediation strategy;
- the use of a technical methodology and analytical model which are in accordance with the statutory requirements, UK guidance and best practice.

Reason: To ensure that the Site is remediated to support the Development and that human health and controlled waters are safeguarded in accordance with London Plan policy 5.21, LB Newham saved policyEQ49 and LB Tower Hamlets saved policy DEV.51.

Remediation Protection Method Statement

OST.73 Where the Global Conceptual Site Model is validated by the remediation statement submitted for approval pursuant to condition OST 72 a remediation protection method statement (RPMS) for the relevant PDZ for the Site(or such other area as may be agreed with the Local Planning Authority in writing) shall be submitted to the Local Planning Authority for approval and no Development works which affect or are below the existing contamination remediation marker layer shall be Commenced until the RPMS is approved. The Remediation Works identified in the RPMS shall be carried out, completed and validated in accordance with the approved RPMS. Each RPMS shall contain as a minimum:

- an outline of general work methodology, including details of proposed plant and equipment to be used;
- measures and controls to protect integrity of existing remediation works carried out under the Olympic Consents including in particular the Protection Layer in accordance with statutory requirements, UK guidance and best practice;
- the location of the proposed operations;
- a programme for implementing the proposed Remediation Works and operations;
- general health and safety and environmental controls;
- details of any required environmental authorisations; and
- details of how the Remediation Works will be validated.

Reason: To ensure that the Site is remediated to support the Development and that human health and controlled waters are safeguarded.

OST.74 Where the Global Conceptual Site Model is not validated by the remediation statement submitted for approval pursuant to condition OST 72 , no Development shall be Commenced unless and until:

- a site specific remediation strategy has been submitted to and approved by the Local Planning Authority pursuant to condition OST 75; and
- a remediation method statement has been submitted to and approved by the Local Planning Authority pursuant to condition OST 76.

and the Remediation Works identified in the approved site specific remediation strategy and remediation method statement shall be carried out, completed and validated in accordance with the methodology and programme contained within those approved documents.

Reason: To ensure that all Remediation Works are properly carried out in accordance with London Plan policy 5.21, LB Newham saved policyEQ49 and LB Tower Hamlets saved policy DEV.51

Site Specific Remediation Strategy

OST.75 Where the Global Conceptual Site Model is not validated by a Remediation Statement submitted pursuant to condition OST 72 a site specific remediation strategy ("SSRS") for the relevant Planning Delivery Zone within the Site(or such other area as may be agreed with the Local Planning Authority in writing) shall be submitted to the Local Planning Authority for approval. Each SSRS shall contain as a minimum:

- details of the precise location of Remediation Works proposed, including earth movements, earthworks filing, licensing and regulatory liaison, health, safety and environmental controls, controls on the quality of imported materials and any validation requirements;
- a position statement on the available and previously completed site investigation information including all consolidated validation reports, enabling works reports, follow-on projects and validation data (including validation chemical dataset from enabling works and follow-on projects) submitted under the Olympic Consents;
- details as to maintaining the integrity of the Protection Layer and the integrity of other remediation works undertaken under the Olympic Consents;
- a rationale for the further site investigations required, including details of the locations of such investigations, the methodologies, sampling and monitoring proposed;
- the proposed GAC and GWAC to be used in the SSRS;
- an assessment of data against GAC and GWAC and if risks are identified then detailed quantitative risk assessment (as identified in the global remediation strategy) is to be undertaken to generate site specific assessment criteria; and
- a programme for implementing the Remediation Works.

Reason: To ensure that all Remediation Works are properly carried out in accordance with London Plan policy 5.21, LB Newham saved policyEQ49 and LB Tower Hamlets saved policy DEV.51

Remediation Method Statement

OST.76 Where the Global Conceptual Site Model is not validated by a remediation statement submitted pursuant to condition OST 72 , a remediation method statement for the relevant Planning Delivery Zone within the Site (or such other area as may be agreed with the Local Planning Authority in writing) shall be submitted to the Local Planning Authority for approval. Each remediation method statement shall contain as a minimum:

- a remediation options appraisal;
- details of remedial techniques to be employed (including if required any soil treatment/process centres and an appropriate marker layer) in accordance with statutory requirements, UK guidance and best practice;
- the locations where those techniques will be used;
- the type and areas of contaminated material to be remediated;
- plant and equipment to be used;
- emissions and control measures and any required environmental authorisations; and
- a programme for implementing the Remediation Works;
- details of how the Remediation Works will be validated (e.g. sampling frequencies, chemical testing sites and the generic assessment criteria and site specific assessment criteria to be used to validate the works)

Reason: To ensure that the Site is remediated to support the Development and that human health and controlled waters are safeguarded in accordance with London Plan policy 5.21, LB Newham saved policy EQ49 and LB Tower Hamlets saved policy DEV.51

Remediation Works

OST.77 Unless otherwise agreed in writing with the Local Planning Authority, monthly progress reports shall be submitted to the Local Planning Authority during the Remediation Works.

Reason: To ensure that all Remediation Works are properly carried out in accordance with London Plan policy 5.21, LB Newham saved policy EQ49 and LB Tower Hamlets saved policy DEV.51

OST.76 Within 12 weeks of the Remediation Works set out in the approved remediation protection method statement, site specific remediation strategy and remediation method statement commencing within the relevant Planning Delivery Zone within the Site (or such other area as may be agreed in advance with the Local Planning Authority in writing), any additional site investigations undertaken during the Remediation Works are to be reported as an addendum to the relevant remediation protection method statement, site specific remediation strategy or remediation method statement which shall be submitted to the Local Planning Authority for approval.

Reason: To ensure that all Remediation Works are properly carried out in accordance with London Plan policy 5.21, LB Newham saved policy EQ49 and LB Tower Hamlets saved policy DEV.51.

Remediation validation and protection

OST.77 Validation of the Remediation Works to show they have been undertaken in accordance with the approved remediation protection method statement, site specific remediation strategy and remediation method statement for the purposes of human health protection and for the protection of controlled waters shall be undertaken on completion of the relevant Remediation Works and a Validation Report shall be submitted within two months of completion of the relevant Remediation Works to the Local Planning Authority and other stakeholders notified by the Local Planning Authority for approval by the Local Planning Authority. When all Remediation Works necessary for the protection of controlled waters and for the protection of human health are completed, a consolidated Validation Report shall be submitted to the Local Planning Authority. This consolidated Validation Report shall include detailed topographic mapping of the as-built ground levels.

Reason: To ensure that all Remediation Works are properly validated and recorded in accordance with London Plan policy 5.21, LB Newham saved policy EQ49 and LB Tower Hamlets saved policy DEV.51.

OST.78 Approved post-remediation monitoring and maintenance of the remediated land shall continue, as set out in the Validation Reports, until such dates or events as are approved by the Local Planning Authority.

Reason: To ensure the protection of human health and avoidance of pollution of controlled waters in accordance with London Plan policy 5.21, LB Newham saved policy EQ49 and LB Tower Hamlets saved policy DEV.51.

Foundation details

OST.79 Before the construction of any part of the Development requiring foundations or the installation of any technology which may require piling is commenced, details of the foundations and piling and a piling risk assessment which shall include as a minimum:

- a method statement for any piling;
- the means by which previously installed remediation measures, including in particular and without limitation the Protection Layer, are to be safeguarded and the integrity maintained;
- a gas/vapour assessment to identify any measures necessary to prevent ingress of gaseous contaminants into that building or structure or the contamination of controlled waters; and
- demonstrating that there is no resultant unacceptable risk to groundwater or increase in the risk of near-surface pollutants migrating into deeper geological formations and aquifers

shall be submitted to and approved by the Local Planning Authority. The approved details shall thereafter be implemented during the construction of the development (or relevant part thereof).

Reason: To avoid risk to human health or contamination of controlled waters in accordance with London Plan policy 5.21, LB Newham saved policy EQ49 and LB Tower Hamlets saved policy DEV.51

Unexpected contamination

- OST.80 If at any time during the construction of the Development and/or the Remediation Works, including demolition, re-profiling, removal of structures, breaking up of roads and hard standing and utilities drainage, contamination is encountered in a Planning Delivery Zone within the Site (including any contaminants of concern not previously identified) which was not previously identified or treated in the course of site investigation or has been brought to the surface by construction activity or is wholly or partly derived from a different source or is of a different type to that identified, no further Development in that Planning Delivery Zone shall take place (except to the extent that it has been agreed with the Local Planning Authority in writing that specified works would not further disturb that contamination) until a Remediation Change Note (which shall be an amendment to the relevant site specific remediation strategy) and/or a revised remediation protection method statement or a revised remediation method statement, containing an assessment of that contamination and a scheme and timetable to contain, treat or remove it, has been submitted to and approved by the Local Planning Authority and any necessary remediation has been carried out. A Remediation Change Note and/or revised remediation protection method statement or revised remediation method statement shall be submitted to the Local Planning Authority within 7 days of any unexpected contamination being encountered.

Reason: To ensure that any contamination discovered during construction is properly remediated and to ensure the protection of human health and avoidance of pollution of controlled waters in accordance with London Plan policy 5.21, LB Newham saved policy EQ49 and LB Tower Hamlets saved policy DEV.51

Quality of imported fill

- OST.81 No soils or infill materials (including silt dredged from watercourses), shall be imported onto the Site or from one Olympic Park Planning Delivery Zone to another until it has been satisfactorily demonstrated to the Local Planning Authority that they present no risk to human health, planting and the environment. Material import requirements including control levels and validation details are to be included within each remediation protection method statement, site specific remediation strategy and remediation method statement. Documentary evidence to confirm the origin of all imported soils and infill materials, supported by appropriate chemical analysis test results, shall be submitted to and approved by the Local Planning Authority prior to that import. The import onto the Site or from one Planning Delivery Zone to another of material classified as 'waste' is only acceptable with the prior approval of the Local Planning Authority and subject always to the obtaining of any required permits in accordance with environmental permitting regulations current at the time, including the duty of care and any transportation requirements by an appropriately registered carrier.

Reason: To ensure that no contaminated material is brought onto Site in accordance with London Plan policy 5.21, LB Newham saved policy EQ49 and LB Tower Hamlets saved policy DEV.51.

Treatment Centres

- OST.82 A specific treatment remediation method statement ("STRMS") shall be prepared for any soil treatment process that is to be operated on the Site and the STRMS shall be submitted to and approved by the Local Planning Authority prior to the commencement of operation of the relevant soil treatment process.

Reason: To avoid risk to human health or contamination of controlled waters in accordance with London Plan policy 5.21, LB Newham saved policy EQ49 and LB Tower Hamlets saved policy DEV.51.

Sustainability

OST.83 All retained stadium elements shall achieve a BREEAM excellent rating with a minimum 70% score of available credits to be achieved in accordance with an assessment schedule which has been submitted to and approved by the Local Planning Authority. There shall be no Operation of the Development until a final certificate has been issued which confirms that a BREEAM Excellent standard has been achieved.

Reason : To ensure a high standard of sustainable design and construction in accordance with London Plan policies 5.1, 5.2, 5.6 and 5.7 and LB Newham Core Strategy policies SC1, SC2 and INF4.

OST.84 All new buildings in the Development shall achieve a BREEAM Excellent rating with a minimum 70% score of available credits to be achieved in accordance with an assessment schedule which has been submitted to and approved by the Local Planning Authority. There shall be no Operation of the Development until a final certificate has been issued which confirms that a BREEAM Excellent standard has been achieved.

The new buildings in the Development shall achieve as a minimum the following CO2 emission reduction targets:

- 25% improvement on 2010 Building Regulations in the period to 2013
- 40% improvement on 2010 Building Regulations from 2013

Reason: To ensure a high standard of sustainable design and construction in accordance with London Plan policies 5.1, 5.2, 5.6 and 5.7 and LB Newham Core Strategy policies SC1, SC2 and INF4.

OST.85 The Development shall achieve a 9% reduction in regulated CO2 emissions through the use of Olympic Park renewable energy generation sources, such reduction to be calculated across all buildings.

Reason: To ensure a high standard of sustainable design and construction in accordance with London Plan policies 5.1, 5.2, 5.6 and 5.7 and LB Newham Core Strategy policies SC1, SC2 and INF4.

OST.86 The retained and transformed building elements in the Development shall achieve as a minimum a 15% reduction in predicted regulated energy demand above 2006 Building Regulations.

Reason: To optimise the standards of sustainable design and construction in accordance with London Plan policies 5.1, 5.2, 5.6 and 5.7 and LB Newham Core Strategy policies SC1, SC2 and INF4.

OST.87 The Development shall be connected to the district heating system and shall not be Operated until confirmation of such connection has been submitted to and approved by the Local Planning Authority. In the event that such a connection is not achieved, the development shall not be Operated until details of other measures necessary to meet the 50% carbon reduction Olympic Park target as required under the Olympic Consents have been submitted to and approved by the Local Planning Authority. Such approved measures shall be installed or undertaken prior to the occupation of the Development.

Reason: To ensure a high standard of sustainable design and construction in accordance with London Plan policies 5.1, 5.2, 5.6 and 5.7 and LB Newham Core Strategy policies SC1, SC2 and INF4.

OST.88 The Development shall have installed at the time of construction smart meters (meaning a meter and any associated or ancillary devices which enables information to be communicated to or from it, using an external electronic communications network) for measuring the supply of electricity, gas and water consumption which shall as a minimum be designed to inform the operators of the level of energy use and in order that such information can be shared as part of the annual monitoring report required to be submitted pursuant to condition OST 89.

Reason: To optimise the standards of sustainable design and construction in accordance with London Plan policies 5.1, 5.2, 5.6 and 5.7 and LB Newham Core Strategy policies SC1, SC2 and INF4.

OST.89 Following the first Operation of the Development the monitoring information in relation to the Development as set out below shall be provided to the Local Planning Authority on not less than an annual basis:

- Electricity, gas and water consumption as a whole;
- percentage of energy requirements sourced from On Site renewable energy generation sources
- water use

The first such monitoring information shall be provided on the first anniversary of first Operation of the Development and on each anniversary thereafter until 5 years from the Completion of Development.

Reason: To optimise the standards of sustainable design and construction and to ensure sufficient information is available to monitor the effects of the development in accordance with London Plan policies 5.1, 5.2, 5.6 and 5.7 and LB Newham Core Strategy policies SC1, SC2 and INF4.

OST.90 The Development shall be designed to minimise the consumption of potable and non-potable water use in accordance with the measures set out in the Sustainability Statement. A 40% reduction in potable water use shall be achieved across all buildings within the Development when compared with 2006 industry standards.

Reason: To optimise the standards of sustainable design and construction and to ensure sufficient information is available to monitor the effects of the development in accordance with London Plan policy 5.15 and LB Newham Core Strategy policy SC1.

OST.91 Before 30th December 2013 a water statement shall be submitted to and approved by the Local Planning Authority which confirms:

- whether the development will connect into a non-potable water network and if so, that a 43% potable water reduction target can be achieved;
- if a connection into a non-potable network is not feasible, which other measures to reduce potable water use (including but not limited to grey water recycling, rainwater harvesting and local sewage treatment) have been considered.

Reason: To optimise the standards of sustainable design and construction and to ensure sufficient information is available to monitor the effects of the development in accordance with London Plan policy 5.15 and LB Newham Core Strategy policy SC1

OST.92 Prior to the Operation of the Development an operational waste management strategy shall be submitted to and approved by the Local Planning Authority. The Strategy shall include targets for waste reduction and a monitoring regime against which progress against the identified targets can be reviewed at least an annual basis.

Reason: To optimise the standards of sustainable design and construction and to ensure sufficient information is available to monitor the effects of the development in accordance with London Plan policy 5.16 and LB Newham Core Strategy policy SC1.

Transport

OST.93 The Development shall not be Operated unless and until a travel plan coordinator has been appointed or nominated in accordance with terms of reference which have been submitted to and approved by the Local Planning Authority. The travel plan coordinator shall remain appointed and operate in accordance with the details so approved.

Reason: To ensure a travel plan coordinator is appointed to oversee the travel plans in order to encourage the use of sustainable travel modes in accordance with London Plan policy 6.1 and LB Newham Core Strategy policy INF2.

OST.94 The Development shall not be Operated until a travel plan steering group has been established in accordance with the details and a terms of reference which has been submitted to and approved by the Local Planning Authority. The travel plan steering group shall thereafter remain convened and operate in accordance with the details so approved.

Reason: To ensure the Development is managed in accordance with the approved details and within the parameters assessed pursuant to the Environmental Statement and in order to encourage the use of sustainable travel modes in accordance with London Plan policy 6.1 and LB Newham Core Strategy policy INF2.

OST.95 The Development shall not be Operated until a Non Event Day travel plan has been submitted to and approved by the Local Planning Authority. The scope of the Non Event Day travel plan shall be agreed in advance with the Local Planning Authority and shall include as a minimum:

- Agreed Mode Share Targets
- Travel plan management structures, including role of travel plan coordinator
- Travel plan communications strategy
- Measures to achieve mode share targets, including
 - measures to encourage cycling and walking
 - measures to encourage car sharing and minimise car use
 - measures to encourage public transport use
- Business travel policies
- Visitor travel information
- Car park management measures
- Monitoring and review processes and schedule

The Development shall be Operated on Non Event Days in accordance with the approved Non Event Day travel plan.

Reason: To ensure the Development is managed in accordance with the approved details and within the parameters assessed pursuant to the Environmental Statement and in order to

encourage the use of sustainable travel modes in accordance with London Plan policy 6.1 and LB Newham Core Strategy policy INF2.

OST.96 The Development shall not be Operated until Event Day and Sports Event Day travel plans have been submitted to and approved by the Local Planning Authority. The scope of the Event Day and Sports Events Day travel plans shall be agreed in advance with the Local Planning Authority and shall include as a minimum:

- Agreed Mode Share Targets
- Travel plan management structures, including role of travel plan coordinator
- Transport information plan and communications strategy
- Measures to encourage sustainable travel patterns amongst spectators and achieve mode share targets including specific measures relating to bus, rail, coaches, cycling and walking
- Car park management measures
- Post-match retention measures
- Monitoring and review processes and schedule

The Development shall be Operated on Event Days and Sports Event Days in accordance with the approved Event Day and Sports Event Day travel plans.

Reason: To ensure the Development is managed in accordance with the approved details and within the parameters assessed pursuant to the Environmental Statement and in order to encourage the use of sustainable travel modes in accordance with London Plan policy 6.1 and LB Newham Core Strategy policy INF2.

OST.97 Car parking provision at the Development shall not exceed 257 spaces in total in connection with Events and Sports Events. A maximum of 55 spaces shall be made available for use on Non Event Days and Non Sports Event Days in connection with the Operation of the Stadium and a maximum of 28 spaces shall be made available for use on Non Event Days and Non Sports Event Days in connection with the Operation of the community athletics track and its related sports facilities. The details of how the balance of car parking at the Development which is not to be used on Non Event Days and Non Sports Event Days is to be secured to prevent its use shall be submitted to and approved by the Local Planning Authority prior to the first Operation of the development.

Reason: To ensure the Development is managed in accordance with the approved details and within the parameters assessed pursuant to the Environmental Statement and in order to encourage the use of sustainable travel modes in accordance with London Plan policy 6.1, 6.13 and LB Newham Core Strategy policy INF2.

OST.98 The Development shall not be Operated until a coach parking strategy has been submitted to and approved by the Local Planning Authority. The scope of the strategy shall be agreed in advance with the Local planning Authority and includes as a minimum:

- Designated coach parking areas
- Management and control of coach parking and drop-off and pick-up areas;
- Measures to encourage coach use
- Monitoring and review of the provision within the Olympic Park.

The Development shall be Operated in accordance with the approved coach parking strategy.

Reason: To ensure the Development is managed in accordance with the approved details and within the parameters assessed pursuant to the Environmental Statement and in order to encourage the use of sustainable travel modes in accordance with London Plan policy 6.1, 6.13 and LB Newham Core Strategy policy INF2

OST.99 The Development shall not be Operated until a taxi management strategy has been submitted to and approved by the Local Planning Authority. The scope of the strategy shall be agreed in advance with the Local planning Authority and includes as a minimum:

- Identification of permanent and temporary Event Day and Sports Event Day provision within the Olympic Park;
- Management of taxi and private hire operation to serve the Stadium;
- Monitoring and review of the provision within the Olympic Park..

The Development shall be Operated in accordance with the approved taxi management strategy.

Reason: To ensure the Development is managed in accordance with the approved details and within the parameters assessed pursuant to the Environmental Statement and in order to encourage the use of sustainable travel modes in accordance with London Plan policy 6.1 and LB Newham Core Strategy policy INF2.

OST.100 The Development shall not be Operated until a minimum of 410 cycle parking spaces have been provided in accordance with the details to be submitted to and approved by the Local Planning Authority and made available for public use. The Development shall not be Operated until a minimum of 24 cycle parking spaces have been made available within the Site for staff use on Non Event Days and Non Sports Event Days.

Reason: To ensure that a suitable level of cycle parking is provided as part of the Development in accordance with London Plan policy 6.9 and LB Newham Core Strategy policy INF2.

OST.101 The Development shall not be Operated until a delivery and servicing strategy has been submitted to and approved by the Local Planning Authority. The scope of the strategy shall be agreed in advance with the Local planning Authority and shall include as a minimum:

- possible measures which could reduce the number of trips and/or impact upon residents of the Development of servicing, deliveries and collections;
- the feasibility of agreed delivery and collection points to enable efficiency of servicing and deliveries and assist occupiers of the Development;
- possible measures to reduce the impact of deliveries and servicing on the environment including improving the efficiency of the delivery of goods and services

The Development shall be Operated in accordance with the approved delivery and servicing strategy.

Reason: To ensure the Development is managed in accordance with the approved details and within the parameters assessed pursuant to the Environmental Statement and in order to encourage the use of sustainable travel modes in accordance with London Plan policy 6.1 and LB Newham Core Strategy policy INF2

Open Space and BAP

Biodiversity Habitat

OST.102 Not less than 3.44 ha of BAP Habitat shall be provided within Planning Delivery Zone 3 prior to the Operation of the Development.

Reason: As a contribution towards the minimum provision of 45ha BAP Habitat in the Olympic Park and in accordance with London Plan policy 7.19 and LB Newham Core Strategy policy SC4.

OST.103 All BAP Habitat within the Site shall be implemented, monitored, managed and maintained in accordance with the Olympic Park Biodiversity Action Plan approved pursuant to the Olympic Consents and the Legacy Communities Scheme Development planning permission.

Reason: To meet the requirements of the Olympic Park BAP and in accordance with London Plan policy 7.19 and LB Newham Core Strategy policy SC4.

Open Space Provision

OST.104 Not less than 14.4ha of Publicly Accessible Open Space shall be provided within the Planning Delivery Zone 3 prior to the Operation of the Development.

Reason: As a contribution towards the minimum provision of 102ha of Publicly Accessible Open Space in the Olympic Park and in accordance with London Plan policies 2.18 and 7.18 and LB Newham Core Strategy policy INF6.

Protection of trees and habitats

OST.105 The Development shall not be Commenced until a plan of existing trees and habitat to be safeguarded (during construction of the Development and during the life of the Development) within the Site has been submitted to and approved by the Local Planning Authority. The trees to be retained and existing habitats shown on the approved plan, or any replacement plan approved by the Local Planning Authority, shall be safeguarded during the construction of the Development and during the life of the Development. No safeguarded tree shall be lopped or felled without the prior approval of the Local Planning Authority.

Reason: To ensure that trees and habitats are protected in accordance with London Plan policies 7.5 and 7.21 and LB Newham Core Strategy policy SP3 and saved policy EQ15.

Event Management

Event Management Plans

OST.106 The Development shall not be Operated until event management plans for Sports Events and Events have been submitted to and approved by the Local Planning Authority. The scope of the event management plans shall be in accordance with the requirements of condition OST 107.

Details of the frequency of the submission of event management plans shall be agreed in writing by the Local Planning Authority prior to the submission of the first event management plan, but prior to the first Operation of the Development there shall be at least one Sports Events event management plan and one Events event management plan that have been submitted to and approved by the Local Planning Authority covering the first calendar year of Operation. Thereafter, the events management plan may be prepared and submitted for approval as a joint document covering both Events and Sports Events or as separate documents.

Reason: To ensure that the Development is Operated within the parameters assessed pursuant to the Environmental Statement and to safeguard the amenities of sensitive receptors from the use of the stadium London Plan policies 6.1 and 7.15 and LB Newham Core Strategy policy INF2 and saved policies EQ45 and EQ48.

Event Management Plan scope

OST.107 The scope of the event management plans shall be based upon the contents of the Framework Event Management Plan and shall include as a minimum:

- Car and cycle Parking
- Coach parking
- Event Day parking scheme
- Traffic management plan including road closures
- Management of arriving and departing spectators
- Crowd modelling including arrival and departure profiles
- Station operations
- Public realm and CCTV cameras
- Management of licensed temporary vending
- Taxis
- Street cleaning
- Security
- Waterways
- Transport information plan and communications strategy
- Stakeholder engagement and meetings, reporting lines and communications
- Monitoring and review processes
- Structure of roles and responsibilities between the various stakeholders

- List of notified organisations
- Dispersion modelling, if not submitted as part of a noise management plan covering the relevant Event or Sports Event;
- Mitigation measures to enable Events operation after 2230;
- Confirmation of how the event management plan dovetails and coordinates with other approved strategies, frameworks, management plans and statements for development within the Olympic Park.

Reason: To ensure that the Development is Operated within the parameters assessed pursuant to the Environmental Statement and to safeguard the amenities of sensitive receptors from the use of the stadium in accordance with London Plan policies 6.1 and 7.15 and LB Newham Core Strategy policy INF2 and saved policies EQ45 and EQ48.

Event Management Plan Compliance

OST.108 No Events and Sports Events shall be held at the stadium other than in accordance with the approved events management plan for that Event or Sports Event.

Reason: To ensure that the Development is Operated within the parameters assessed pursuant to the Environmental Statement and to safeguard the amenities of sensitive receptors from the use of the stadium in accordance with London Plan policies 6.1 and 7.15 and LB Newham Core Strategy policy INF2 and saved policies EQ45 and EQ48.

Event Management Coordinator

OST.109 The Development shall not be Operated unless and until an event management coordinator has been appointed or nominated and evidence of the same provided has been to the Local Planning Authority. An event management coordinator shall be retained or nominated at all times throughout the Operation of the Development and shall be responsible for the following:

- submitting event management plans and noise management plans to the Local Planning Authority;
- monitoring compliance with the measures set out in the approved event management plan and noise management plan
- submitting compliance monitoring reports
- Convening the community liaison group

Reason: To ensure that the Development is Operated within the parameters assessed pursuant to the Environmental Statement and to safeguard the amenities of sensitive receptors from the use of the stadium in accordance with London Plan policies 6.1 and 7.15 and LB Newham Core Strategy policy INF2 and saved policies EQ45 and EQ48.

Event Management Coordination Framework

OST.110 The Development shall not be operated unless and until the Events Management Coordination Framework for the Olympic Park, pursuant to conditions LTD.26 of the Olympic Consents and condition LCS.0249 of the Legacy Communities Scheme Development planning permission has been submitted to and approved by the Local Planning Authority. The Development shall be operated in accordance with the approved Events Management Coordination Framework for the Olympic Park.

Reason: To ensure that the Development is Operated in coordination with other Events within the Olympic Park and within the parameters assessed pursuant to the Environmental Statement and to safeguard the amenities of sensitive receptors from the use of the stadium in accordance with London Plan policies 6.1 and 7.15 and LB Newham Core Strategy policy INF2 and saved policies EQ45 and EQ48.

Noise

Noise Management Plan

- OST.111 The Development shall not be Operated until noise management plans for Sports Events and Events have been submitted to and approved by the Local Planning Authority. The scope of the noise management plans shall be in accordance with the requirements of condition OST 112.

Details of the frequency of the submission of noise management plans shall be agreed in writing by the Local Planning Authority prior to the submission of the first noise management plan, but prior to the first Operation of the Development there shall have been at least one Sports Events noise management plan and one Events noise management plan submitted to and approved by the LPA covering the first calendar year of Operation. Thereafter, the noise management plans may be prepared and submitted to the Local Planning Authority for approval as a joint document covering both Events and Sports Events or as separate documents.

Reason: To ensure that the Development is Operated within the parameters assessed pursuant to the Environmental Statement and to safeguard the amenities of sensitive receptors from the use of the stadium London Plan policy 7.15 and LB Newham saved policies EQ45 and EQ48.

Noise Management Plan scope

- OST.112 The scope of the noise management plans shall be based upon the contents of the draft noise management plan as set out at Annexure 4 of this permission and shall include as a minimum:

- Distribution of pre-event information to the local community
- Liaison with the relevant sound company
- Rehearsals
- Sound propagation tests
- Sound control within the Stadium
- Audience noise exposure and noise contour plot
- Workplace noise exposure
- Sound monitoring in the local community/Off Site
- Music control procedures and monitoring, including cumulative impact
- Complaints monitoring and action plan
- Music noise times and duration
- Dispersion modelling, if not submitted as part of an event management plan covering the Event;
- Mitigation measures to enable operation of Events after 2230;
- Confirmation of how the noise management plan dovetails and coordinates with other approved strategies, frameworks, management plans and statements for development within the Olympic Park.

Reason: To ensure that the Development is Operated within the parameters assessed pursuant to the Environmental Statement and to safeguard the amenities of sensitive receptors from the use of the stadium in accordance with London Plan policy 7.15 and LB Newham saved policies EQ45 and EQ48.

Noise Management Plan Compliance

- OST.113 No Events and Sports Events shall be held at the stadium other than in accordance with the relevant approved noise management plan for that Events or Sports Event.

Reason: To ensure that the Development is Operated within the parameters assessed pursuant to the Environmental Statement and to safeguard the amenities of sensitive receptors from the use of the stadium in accordance with London Plan policy 7.15 and LB Newham saved policies EQ45 and EQ48.

Stadium Public Address system

- OST.114 Prior to the Operation of the Development a scheme for the design, specification and operation of the public address (PA) system such that the LAeqT, measured or calculated at 1m from the façade of the nearest noise sensitive premises, shall not exceed a value equal to the existing LA90 (background noise level) shall be submitted to and approved by the Local Planning Authority. The LAeqT of the PA noise and existing background noise levels shall be determined as per the guidance provided in BS4142:1997. The PA system shall not be used other than for testing and commissioning purposes until the Local Planning Authority has approved the PA system and its operational noise levels in writing.

Reason: To safeguard the amenities of sensitive receptors from the use of the stadium in accordance with London Plan policy 7.15 and LB Newham saved policies EQ45 and EQ48.

Operational Plant Noise and Extract Systems

- OST.115 Before any heating, air conditioning or other plant generating external noise is installed in the Development, details of that plant, including any noise mitigation and predicted noise levels at any sensitive receptor, shall be submitted to and approved by the Local Planning Authority. An assessment shall be submitted following the calculation methodology under BS4142:1997. Where the background noise level can be reliably established, noise levels from the installed plant shall not exceed that background noise level at any sensitive receptor. Where background noise level cannot be reliably established, noise levels from the installed plant shall not exceed 40dB LAeq (5 minutes) at any sensitive receptor.

Reason: To protect the amenities of local residents and users in accordance with London Plan policy 7.15 and LB Newham saved policies EQ45 and EQ48.

- OST.116 The air conditioning, extraction system(s) and any other plant generating external noise installed within those parts of the Development serving kitchens, bars, restaurants, cafe, take away hot food and hospitality accommodation shall be maintained to meet and Guidance on the Control of Odour and Noise from Commercial Kitchen Exhaust Systems (Department for Environment, Food and Rural Affairs, 2005) criteria for the lifetime of the development unless non material changes are otherwise approved in writing by the Local Planning Authority.

Reason: To protect the amenities of local residents and users in accordance with London Plan policy 7.15 and LB Newham saved policies EQ45 and EQ48.

Stadium Management Group

OST.117 The Development shall not be Operated until details as to how a Stadium management group is to be established and operated pursuant to condition OST 118 have been submitted to and approved by the Local Planning Authority. Such details shall include:

- the composition of the Stadium management group;
- the terms of reference of the stadium management group, including how it will work with other Olympic Park management groups; the annual monitoring it will undertake and reports it will produce for example with respect to transport, local employment, local environmental management and community liaison;
- how the Stadium management group is to be administered.

Reason: To ensure the Development is managed in accordance with the approved details and within the parameters assessed pursuant to the Environmental Statement in accordance with London Plan policies 3.19, 6.1 and 7.15 and LB Newham Core Strategy policies SO3, INF2, INF8 and saved policies EQ45 and EQ48.

OST.118 The Development shall not be Operated until a Stadium management group has been established in accordance with the details approved pursuant to condition OST 117 and thereafter shall remain convened and operate in accordance with the details approved under condition OST117

Reason: To ensure the Development is managed in accordance with the approved details and within the parameters assessed pursuant to the Environmental Statement in accordance with London Plan policies 3.19, 6.1 and 7.15 and LB Newham Core Strategy policies SO3, INF2, INF8 and saved policies EQ45 and EQ48.

Community Facilities/Access

OST.119 The Development shall not be Operated until a convergence strategy has been submitted to and approved by the Local Planning Authority. The scope of the strategy shall be agreed in advance with the Local Planning Authority and shall include as a minimum:

- measures to encourage community access to the Stadium and facilities
- annual reporting of progress against employment targets;
- annual reporting of community use targets;
- activity of the community liaison group.

Reason: To report on the progress against convergence objectives as set out in London Plan policies 2.4 and 4.12 and LB Newham Core Strategy policies SO3, J3 and INF8.

OST.121 The Development shall not be operated until details as to how a Stadium community liaison group is to be established and operated have been submitted to and approved by the Local Planning Authority. Such detail shall include:

- the composition of the Stadium community liaison group;
- the terms of reference of the Stadium community liaison group, including how it will work with other Olympic Park management groups;
- the annual monitoring it will undertake and reports it will produce;
- how the community liaison group is to be administered.

The Development shall not be Operated until a Stadium community liaison group has been established in accordance with the approved details and thereafter shall remain convened and operate in accordance with the approved details.

Reason: To ensure the Development is managed in accordance with the approved details and within the parameters assessed pursuant to the Environmental Statement in accordance with London Plan policies 3.19, 6.1 and 7.15 and LB Newham Core Strategy policies SO3, INF2, INF8 and saved policies EQ45 and EQ48.

Rugby World Cup 2015

- OST.122 There shall be no use of the Site for any Rugby World Cup Events until all details of temporary structures and buildings within both front and back of house areas required in connection with hosting the Rugby World Cup 2015 have been submitted to and approved by the Local Planning Authority. All buildings and structures so approved shall be for a temporary period only and shall be removed at the cessation of the Rugby World Cup 2015.

Reason: To ensure that all temporary structures and buildings are removed to ensure that the visual amenities of the area are protected in accordance with policies London Plan policy 7.5 and LB Newham Core Strategy policy SP3.

- OST.123 There shall be no use of the Site for any Rugby World Cup Events until all details of temporary advertisements and signs required in connection with hosting the Rugby World Cup 2015 have been submitted to and approved by the Local Planning Authority. All advertisements and signs so approved shall be for a temporary period only and shall be removed at the cessation of the Rugby World Cup 2015.

Reason: To safeguard visual amenities and public safety in accordance with London Plan policies 7.5 and 7.6 and LB Newham Core Strategy policy SP3.

- OST.124 There shall be no use of the Site for any Rugby World Cup Events until details of temporary access routes to the Stadium from public transport facilities in the surrounding area, the extent of such an area to be agreed in advance with the Local Planning Authority, have been submitted to and approved by the Local Planning Authority. All details so approved shall be made available for use prior to the operation of the Stadium for Rugby World Cup Events.

Reason: To ensure that there are safe and accessible routes to serve the Stadium during the Rugby World Cup Events in accordance with London Plan policy 6.1 and LB Newham Core Strategy Policy INF2.

- OST.125 There shall be no use of the Site for any Rugby World Cup Events until an event management plan for the Rugby World Cup Events has been submitted to and approved by the Local Planning Authority, the scope of which shall be agreed in advance with the Local Planning Authority prior to submission. The use of the Site for Rugby World Cup Events shall only be undertaken in accordance with the approved event management plan.

Reason: To ensure that the development is operated within the parameters assessed pursuant to the Environmental Statement and to sufficient provision is made for crowd management and public safety in accordance with London Plan policies 6.1 and 7.15 and LB Newham Core Strategy policy INF2 and saved policies EQ45 and EQ48.

- OST.126 There shall be no use of the Site for any Rugby World Cup Events until a noise management plan for the Rugby World Cup Events has been submitted to and approved by the Local Planning Authority, the scope of which shall be agreed in advance with the Local Planning

Authority prior to submission. The use of the Site for Rugby World Cup Events shall only be undertaken in accordance with the approved noise management plan.

Reason: To ensure that the development is operated within the parameters assessed pursuant to the Environmental Statement and to protect the amenities of sensitive receptors in accordance with London Plan policy 7.15 and LB Newham saved policies EQ45 and EQ48.

D R A F T

T

OST.127 There shall be no use of the Site for any Rugby World Cup Events until an event travel strategy, including relevant travel plan measures to be agreed in advance with the Local planning Authority, for the Rugby World Cup Events has been submitted to and approved by the Local Planning Authority, the scope of which shall be agreed in advance with the Local Planning Authority prior to submission. The use of the Site for Rugby World Cup Events shall only be undertaken in accordance with the approved event travel strategy.

Reason: To ensure that the development is operated within the parameters assessed pursuant to the Environmental Statement and to manage the transport and access of spectators to the Rugby World Cup Event in accordance with in accordance with London Plan policy 6.1 and LB Newham Core Strategy Policy INF2.

OST.128 The use of the Stadium for Rugby World Cup Events shall take place only between the hours of 0800-2300 Monday to Saturday and 0800-2230 on Sunday.

Reason: To ensure the Development is operated in accordance with the approved details and within the parameters assessed pursuant to the Environmental Statement and to safeguard the amenities of sensitive receptors from the use of the stadium in accordance with London Plan policy 7.15 and LB Newham saved policies EQ45 and EQ48.

OST.129 Outside of the hours of operation for the Rugby World Cup Events use of the Stadium set out in condition OST 128 ancillary start-up and break down operating periods prior to and after each Rugby World Cup Event shall be set out in the approved event management plan and noise management plan for the Rugby World Cup 2015 and which are required to be submitted to the Local planning Authority for approval pursuant to conditions 125 and 126.

Reason: To safeguard the amenities of sensitive receptors from the operation of the stadium in accordance with London Plan policy 7.15 and LB Newham saved policies EQ45 and EQ48.

OST.130 There shall be no use of the Site for any Rugby World Cup Events until such works to bridges H04, F11, F07 and F17 or other interim works to those bridges in order to facilitate crowd movement and access as agreed in advance by the Local Planning Authority in writing, have been implemented and those bridges made available for use in connection with the Rugby World Cup Events.

Reason: In the interests of crowd movement, public access and to mitigate the impact of the development in accordance with London Plan policies 6.1, and 7.13 and LB Newham Core Strategy INF2 and LB Tower Hamlets Core Strategy Policy SO19.

OST.131 Other than for testing purposes, the field of play floodlights in the Stadium and public address system at the Stadium and the Stadium podium shall be limited to use for a period not exceeding two hours prior to the commencement of each of the Rugby World Cup Events but in any case no earlier than 0800 Monday-Sunday. In the case of Rugby World Cup Events finishing at either 2230 Monday-Sunday, the field of play floodlighting within the Stadium and public address system within the Stadium and on the Stadium podium shall not be used after midnight on Monday-Sunday. Specific exceptions to this restriction may be agreed subject to mitigation and other operating restrictions as set out in an approved Rugby World Cup 2015 event management plan or noise management plan approved by the Local Planning Authority pursuant to conditions OST 125 and OST 126 respectively.

Reason: To safeguard the amenities of sensitive receptors from the operation of the stadium in accordance with London Plan policy 7.15 and LB Newham saved policies EQ45 and EQ48.

OST.132 Prior to the use of the Stadium for any Rugby World Cup Events a scheme for the design, specification and operation of the public address (PA) system such that the LAeqT, measured or calculated at 1m from the façade of the nearest noise sensitive premises shall not exceed a value equal to the existing LA90 (background noise level) shall be submitted to and approved by the Local Planning Authority. The LAeqT of the PA noise and existing background noise levels shall be determined as per the guidance provided in BS4142:1997. The PA system shall not be used other than for testing and commissioning purposes until the Local Planning Authority has approved the PA system and its operational noise levels in writing.

Reason: To safeguard the amenities of sensitive receptors from the use of the stadium in accordance with London Plan policy 7.15 and LB Newham saved policies EQ45 and EQ48.

OST.133 There shall be no use of the Site for any Rugby World Cup Events until an operational waste management strategy for the Rugby World Cup Events has been submitted to and approved by the Local Planning Authority. The strategy shall include targets for waste reduction and recycling and how these will be achieved during the operation of Rugby World Cup Events.

Reason: To ensure that the operation of the use minimises waste in accordance with London Plan policy 5.16 and LB Newham Core Strategy policy INF3.

Informatives

Under the terms of the Water Resources Act 1991 and the Land Drainage Byelaws 1981, the prior written consent of the Environment Agency is required for any proposed works or structures in, under, over or within 8 metres of the brink of the City Mill River and Old River Lee main rivers. Please contact the Flood Risk Management department on 01707 632309 for further details.

An Environmental Permit or exemption under the Environmental Permitting Regulations (England and Wales) 2010 may be required for the storage, treatment and re-use of soils, construction and demolition wastes. Please contact the EA Environment Management department on 01707 632413 for further details.

An abstraction licence under the terms of the Water Resources Act 1991 will usually be required if a proposed abstraction will exceed 20 cubic metres of water per day.

Positive and Proactive Statement:

In accordance with the National Planning Policy Framework and with Article 31 of the Town and Country Planning (Development Management Procedure) (England) Order 2010 (as amended), the following statement explains how the LLDC as Local Planning Authority has worked with the applicant in a positive and proactive manner based on seeking solutions to problems arising in relation to dealing with this planning application:

The proposed development has been subject to pre-application discussions between the applicant and the local planning authority which enabled considerations in respect of the proposed development to be discussed at an early opportunity and before the planning application was submitted to the local planning authority.

Following submission of the planning application, the local planning authority continued to work with the applicant in a positive and proactive manner. The applicant responded to the local planning authority through the submission of revisions in order to address the

problems identified by the local planning authority in dealing with the planning application. This solution has enabled planning permission to be granted.

The applicant has been kept informed of the progress of the application and has been given the opportunity to respond to and address any problems arising.

The applicant and the local planning authority have entered into a section 106 agreement, the obligations in which have been a material consideration in the decision to grant planning permission

Dated this:

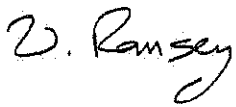

Vivienne Ramsey
Director of Planning Policy and Decisions
London Legacy Development Corporation

DRAFT

T

London Legacy Development Corporation
TOWN AND COUNTRY PLANNING ACT 1990

Appeals to the Secretary of State

- * If you are aggrieved by the decision of your Local Planning Authority to refuse permission for the proposed development or to grant it subject to conditions, then you can appeal to the Secretary of State for the Environment under Section 78 of the Town and Country Planning Act 1990.
- * If you want to appeal then you must do so within SIX months of the date of this notice, using a form, which is available from the Planning Inspectorate, (a copy of which must be sent to London Legacy Development Corporation Planning Policy and Decisions Team) or complete an application online.
The Planning Inspectorate, Temple Quay House, 2 The Square, Temple Quay, Bristol, BS1 6PN (e-mail: enquiries@pins.gsi.gov.uk) or (Tel: 0117 372 8000).
To make an appeal online, please use www.planningportal.gov.uk/pcs. The Inspectorate will publish details of your appeal on the internet. This may include copies of documentation from the original planning application and relevant supporting documents supplied to the local authority, and or information, including personal information belonging to you that you are happy will be made available in this way. If you supply personal information belonging to a third party please ensure you have their permission to do so. More detailed information about data protection and privacy matters is available on the Planning Portal.
- * The Secretary of State can allow a longer period for giving notice of an appeal, but he will not normally be prepared to use this power unless there are special circumstances, which excuse the delay in giving notice of appeal.
- * The Secretary of State need not consider an appeal if it seems to him that the Local Planning Authority could not have granted it without the conditions it imposed, having regard to the statutory requirements, to the provisions of the development order and to any directions given under the order.
- * In practice, the Secretary of State does not refuse to consider appeals solely because the Local Planning Authority based its decision on a direction given by him.

Purchase Notice

- * If either the Local Planning Authority or the Office of the Deputy Prime Minister refuses permission to develop land or grants it subject to conditions, the owner may claim that he can neither put the land to a reasonably beneficial use in its existing state nor can he render the land capable of a reasonably beneficial use by carrying out any development which has been or would be permitted.
- * In these circumstances, the owner may serve a purchase notice on the Council in whose area the land is situated. This notice will require the Council to purchase his interest in the land in accordance with Part VI of the Town and Country Planning Act 1990.

APPENDIX 3
SUPPLEMENTAL SECTION 106 AGREEMENT
FORM OF SUPPLEMENTAL SECTION 106 AGREEMENT
(REQUIRED PURSUANT TO CLAUSE 4.1.3)

DATED 2013

- (1) LONDON LEGACY DEVELOPMENT CORPORATION
- (2) E20 STADIUM LLP

SUPPLEMENTAL PLANNING OBLIGATION BY AGREEMENT

made pursuant to section 106 of the Town and Country Planning Act 1990 and all other powers enabling

relating to the Olympic Stadium located within the Queen Elizabeth Olympic Park



Pinsent Masons

BETWEEN:-

- (1) **LONDON LEGACY DEVELOPMENT CORPORATION LIMITED** of Level 10, 1 Stratford Place, Montfichet Road, London E20 1EJ (the "LPA"); and
- (2) **E20 STADIUM LLP** (a Limited Liability Partnership incorporated in England and Wales with registered number OC376732) whose registered office is at Level 10, 1 Stratford Place, Montfichet Road, London E20 1EJ ("E20").

RECITALS

WHEREAS:-

- (A) The LPA is the local planning authority for the purposes of section 106 of the 1990 Act for the area within which the Site is situated.
- (B) On [] 2013 the LPA and E20 entered into the Principal Agreement.
- (C) E20 had prior to the date of this Agreement an equitable interest only in the Site.
- (D) On [] 201[] the Agreement for Lease became unconditional and as a result E20 has now been granted the Leases.
- (E) This Supplemental Agreement is entered into pursuant to the requirements of Clause 4.1.3 of the Principal Agreement and is entered into for the purpose of confirming that the obligations, covenants and undertakings contained in the Principal Agreement are binding on E20's Legal Interest in the Site for the purposes of the said section 106 of the 1990 Act.

OPERATIVE PROVISIONS:-

1. INTERPRETATION

- 1.1 Save where provided otherwise, words and expressions used in this Supplemental Agreement have the meaning assigned to them in the Principal Agreement.
- 1.2 For the purposes of this Supplemental Agreement, the following words and expressions have the meanings assigned:

"Agreement for Lease" means an agreement dated 22 March 2013 and made between (1) the London Legacy Development Corporation and (2) E20 Stadium LLP;

"Leases" has the meaning given in the Agreement for Lease;

"Principal Agreement" means an agreement dated [] 201[] between the LPA (1) and the E20 (2) and entered into pursuant to section 106 of the 1990 Act and other relevant powers.

2. OPERATION OF THIS SUPPLEMENTAL AGREEMENT

- 2.1 This Supplemental Agreement is supplemental to the Principal Agreement and is entered into pursuant to section 106 of the 1990 and (insofar as this Agreement does

not contain planning obligations), sections 201(1) and (2), 205 and 206 of the Localism Act 2011 and all other powers so enabling.

2.2 The obligations, covenants, undertakings and agreements contained in this Supplemental Agreement and given to the LPA are planning obligations for the purposes of section 106 of the 1990 Act and are enforceable by the LPA as the local planning authority for the area within which the Site is located.

2.3 E20 confirms to and covenants with the LPA that from the date of this Supplemental Agreement its Legal Interest in the Site is bound by the obligations, covenants and undertakings on the part of the Developer contained in the Principal Agreement and that such obligations, covenants and undertakings are planning obligations pursuant to and for the purposes of section 106 of the 1990 Act and so as to bind the Site and, subject to Clauses 2.5 and 2.6 of the Principal Agreement, the said obligations, covenants and undertakings on the part of the Developer in the Principal Agreement are entered into by E20 with the intent that they shall be enforceable not only against E20 but also against any successors in title to or assigns of E20 and/or any person claiming through or under E20 an interest or estate in the Site (other than a Utility Undertaker insofar as and to the extent that the relevant Utility Undertaker is occupying the relevant part of the Site in its capacity as a Utility Undertaker) as if that person had been an original covenanting party in respect of such interest for the time being held by it.

2.4 The LPA covenants with E20 in respect of the Site to perform the obligations, covenants and undertakings on their part contained in the Principal Agreement.

3. **LOCAL LAND CHARGE**

This Supplemental Agreement is a local land charge and shall be registered as such.

IN WITNESS whereof the parties have executed this Deed the day and year first above written

EXECUTED as a deed by affixing the)
Common Seal of **LONDON LEGACY**)
DEVELOPMENT CORPORATION)
)
)
in the presence of : -)

.....

Authorised Signatory

EXECUTED as a deed by **E20 STADIUM LLP**)
acting by its Members **NEWHAM LEGACY**)
INVESTMENTS LIMITED and **LONDON**)
LEGACY DEVELOPMENT CORPORATION)

.....
Director of **NEWHAM LEGACY**
INVESTMENTS LIMITED

.....
Director of **NEWHAM LEGACY**
INVESTMENTS LIMITED

.....
Authorised signatory of **LONDON LEGACY**
DEVELOPMENT CORPORATION

APPENDIX 4
PLAN OF OLYMPIC STADIUM ISLAND

Copyright London Legacy Development Corporation ("LLDC"), 2012. All rights reserved. Except as permitted by the Copyright, Design and Patents Act 1988, no part of this document may be reproduced, stored, transmitted or distributed in any form or by any means, whether electronic, mechanical, by photocopy, recording or otherwise, without prior permission of a director. Except where otherwise expressly agreed in writing, the LLDC shall have no responsibility or liability for any loss (direct, consequential or otherwise) which may arise from the reliance on or use of this document or the information contained in it.

Do not scale this drawing.
Notes:

Handwritten signatures and initials:
KTD
LMD
JCS

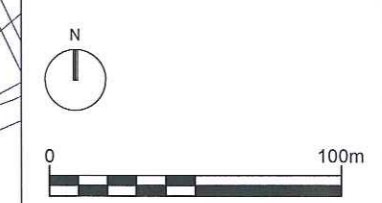

- Olympic Stadium Transformation Planning Application Blue Line
- Olympic Stadium Transformation Planning Application Boundary

Rev	Description	Drawn	chk'd	Date
Creator	Prepared by LDA Design - Hargreaves Associates On behalf of the LLDC			
Drawing Title	Planning Application Plan			
	Sheet 1 of 1			
Project Title	Olympic Stadium Transformation			
Drawn	Checked	Approved		
KJ	CB	NM		
Date	Scale	Size		
June 2012	1:2500	A3		
Purpose of Drawing	Subsidiary			
	Illustrative	D5		
Drawing No.	Sheet	Rev.		
LC201-STA-STA-T-DGA-0001		P01		

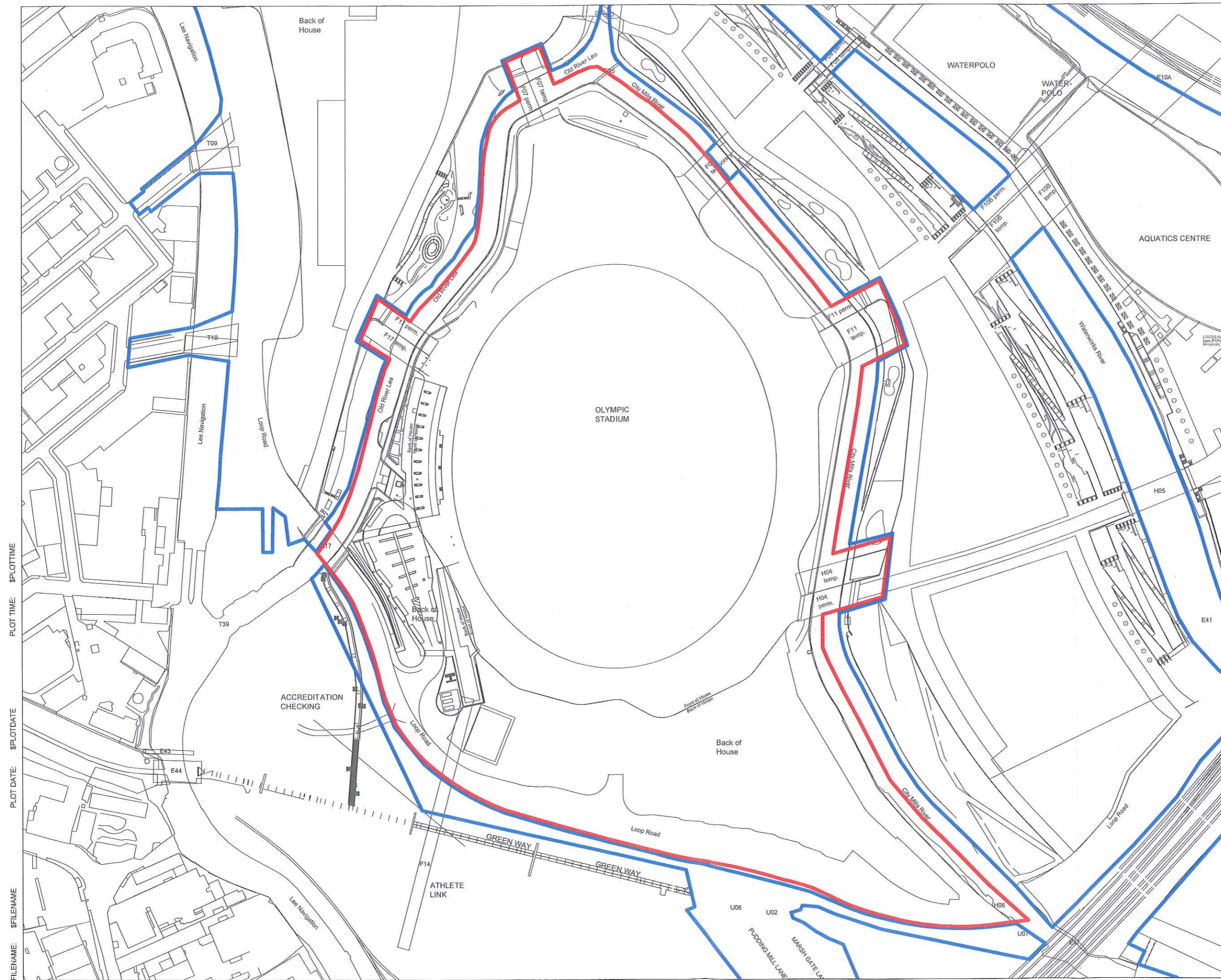

FILENAME: \$FILENAME
PLOT DATE: \$PLOTDATE
PLOT TIME: \$PLOTTIME
\$PLOTDATE
\$PLOTTIME

APPENDIX 5
SITE PLAN

Copyright © Populous Limited 2012. All rights reserved. Except as permitted in writing, no part of this drawing may be reproduced, stored in a retrieval system, or transmitted in any form or by any means, electronic, mechanical, photocopying, recording, or by any information storage and retrieval system.

DO NOT SCALE THIS DRAWING.
NOTES:



Handwritten signatures and initials:
 [Signature]
 [Signature]
 JCS

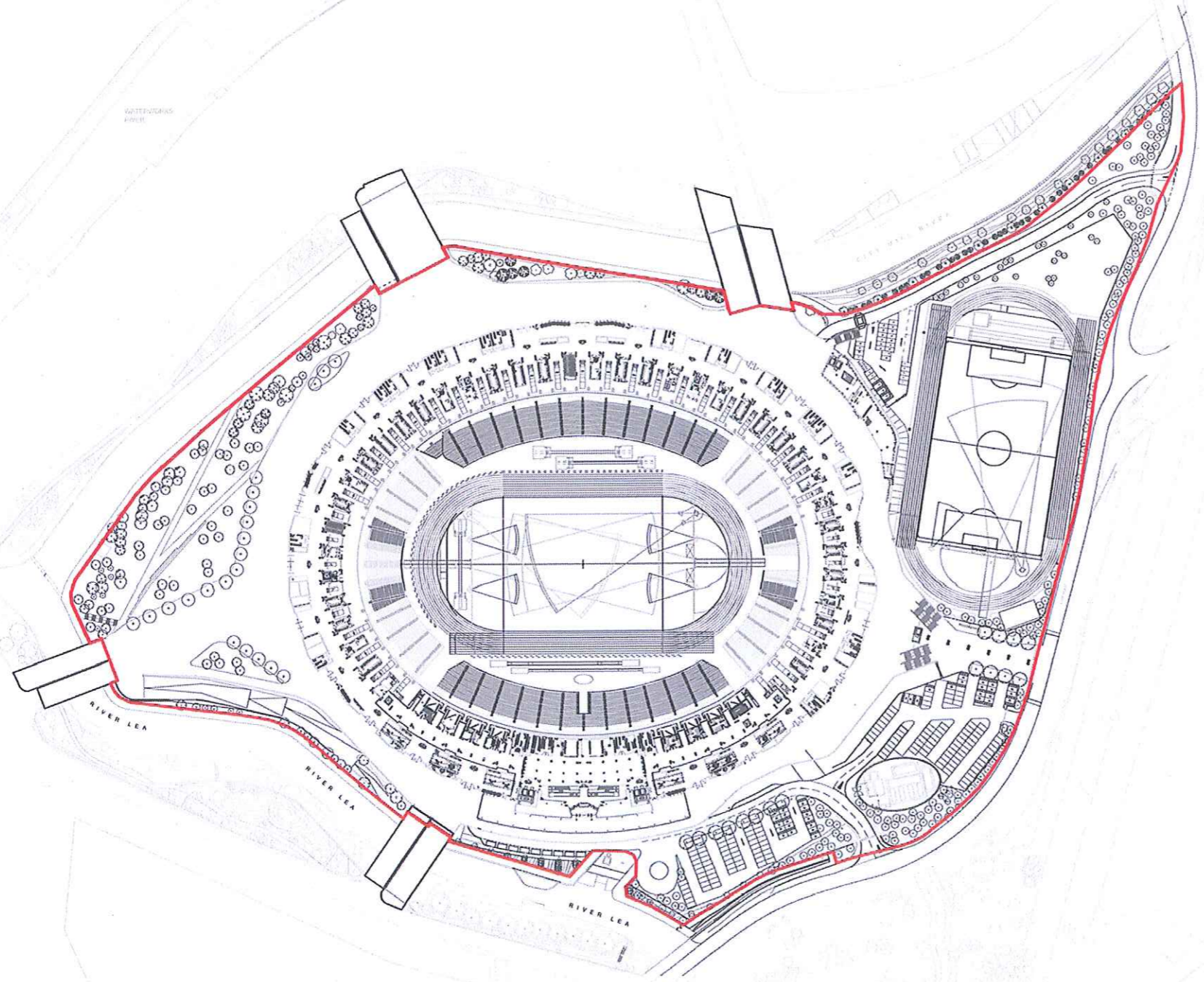

POI	REVISED STAGE D DESIGN FREEZE	MC	PJ	20 11 2012
POI	ISSUED FOR PERMIT REVIEW STAGE D	AL	PJ	20 11 2012
Rev	Description	Drawn	Checked	Estn

SAFETY, HEALTH AND ENVIRONMENT INFORMATION
 Based on the use of experienced and competent contractors working to an approved method statement, standard health and safety and HSE forms where applicable. No other specific risks have been identified, the statement TWO UNUSUAL RISKS is noted.

Construction
 Operations
 Maintenance
 Demolition / Dismantling

POPULOUS™
 14 BLAKE COURT | 2000A ROAD | LEICESTER | LE11 1LW | UNITED KINGDOM
 TELEPHONE: +44 (0)1533 433900 | FAX: +44 (0)1533 433901
 WWW.POPULOUS.COM

PROJECT
OLYMPIC STADIUM TRANSFORMATION (4535)
 CLIENT
LONDON LEGACY DEVELOPMENT CORPORATION
 DRAWING TITLE
**GENERAL ARRANGEMENT
 LEVEL 00 SITE PLAN, PODIUM
 +12.0M (ATHLETICS MODE)**

STATUS				
STAGE D				
DRAWING NUMBER	REV.			
LC201-STA-GND-A-DSP-1000	P02			
DATE	SCALE	QAO	SIZE	NORTH
20/11/2012	1:1000	AD	A0	
DRAWN BY	CHECKED	APPROVED	NOTES	
AL	MA	PJ		

© COPYRIGHT. ALL RIGHTS RESERVED.
 No part of this drawing may be reproduced, stored in a retrieval system, or transmitted in any form or by any means, electronic, mechanical, photocopying, recording, or by any information storage and retrieval system, without the prior written permission of Populous Limited.



APPENDIX 6

PLAN SHOWING EXTENT OF TAXI PICK UP AND DROP OFF MONITORING

Olympic Stadium Transformation

Extent of Taxi Monitoring

JB *CMF* *KB*

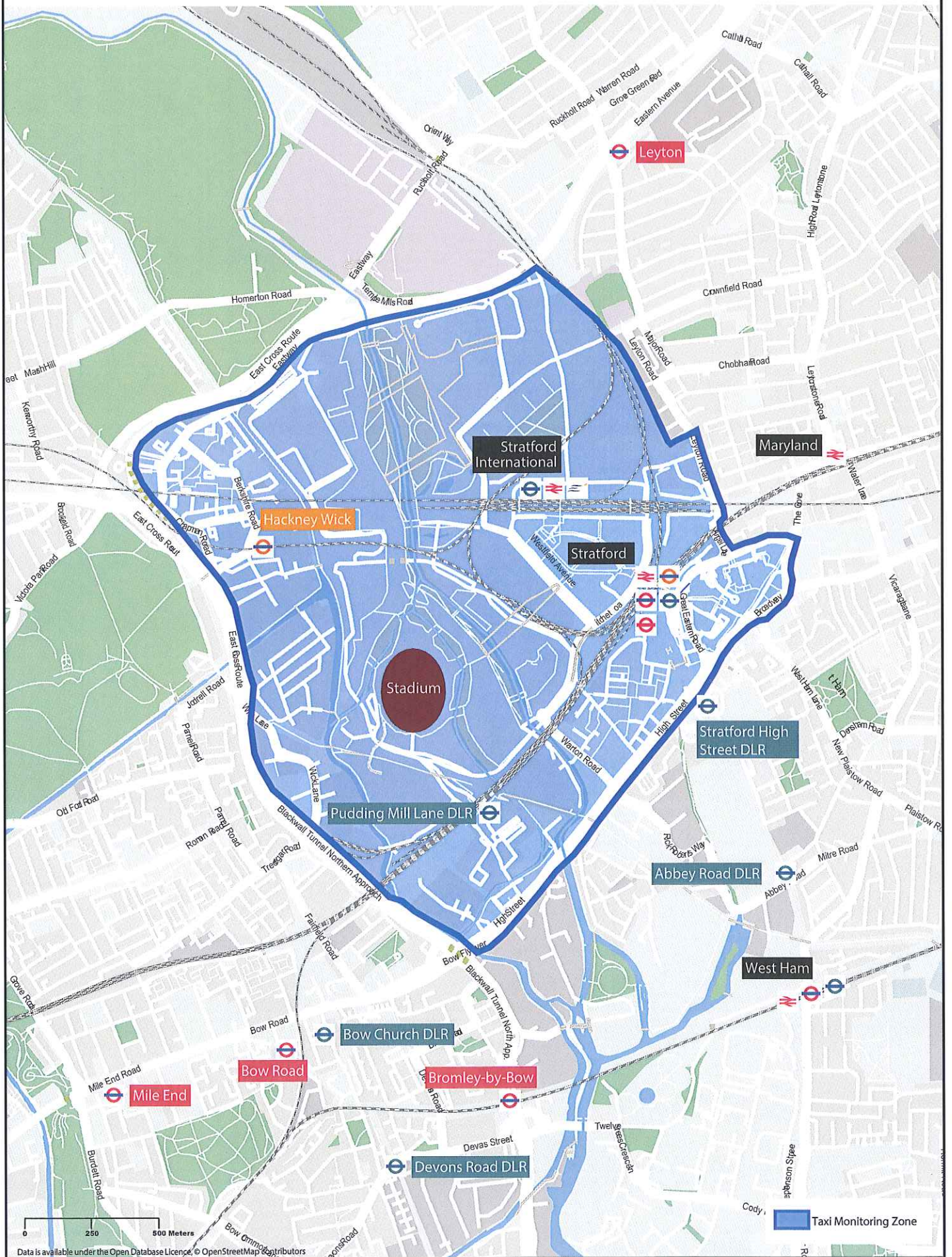

APPENDIX 7

PLAN SHOWING EXTENT OF COACH PICK UP AND DROP OFF MONITORING

Olympic Stadium Transformation

Extent of Coach Monitoring

Handwritten signatures: JB, CP, RD

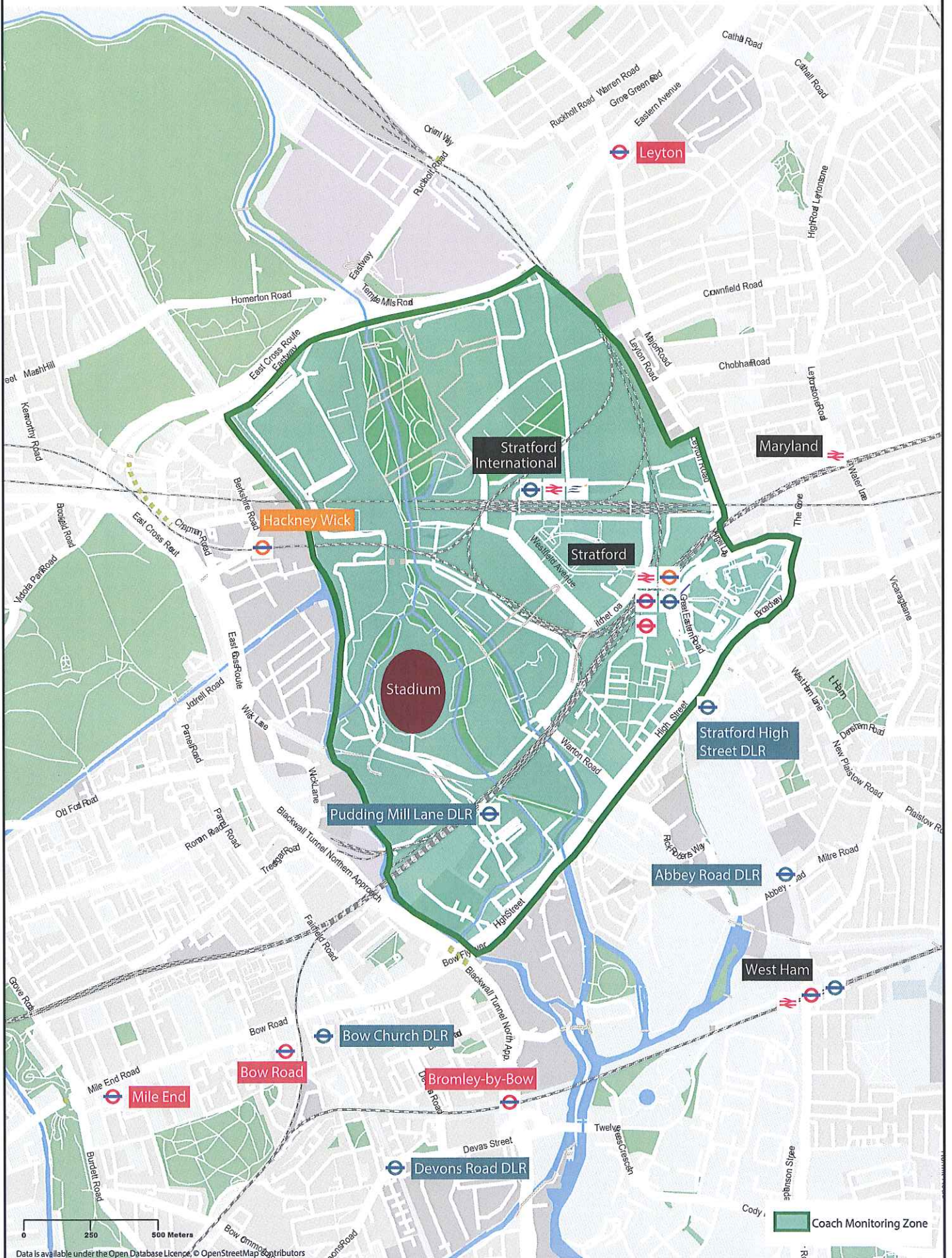

APPENDIX 8
PERMISSIVE PATHS PLAN

Olympic Stadium Transformation
Permissive Paths

Jobs *cut* *X*

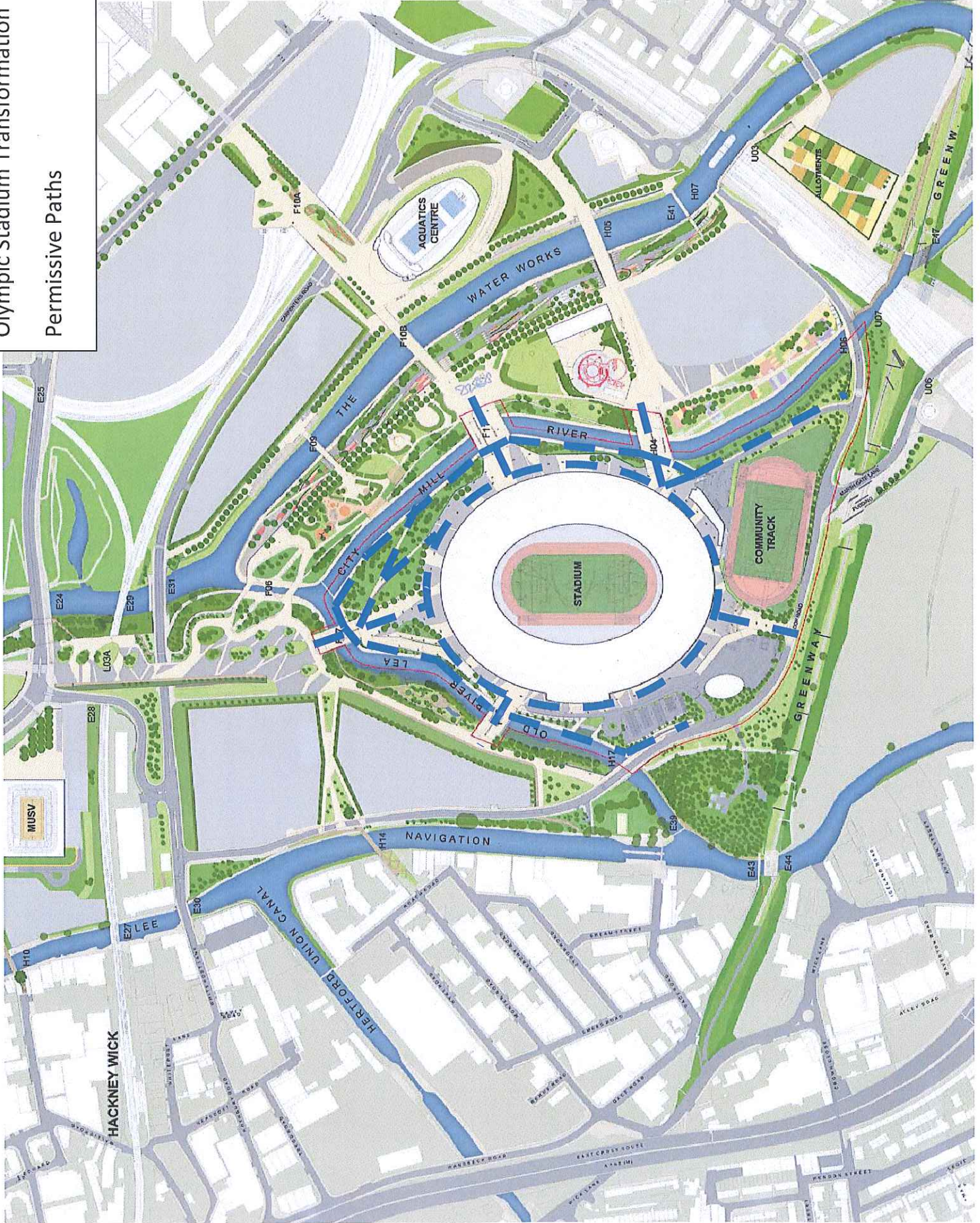

APPENDIX 9
PROPOSED EVENT DAY STADIUM CPZ AREA

Job cut KR

Olympic Stadium Transformation

Extent of Proposed Match Day CPZ

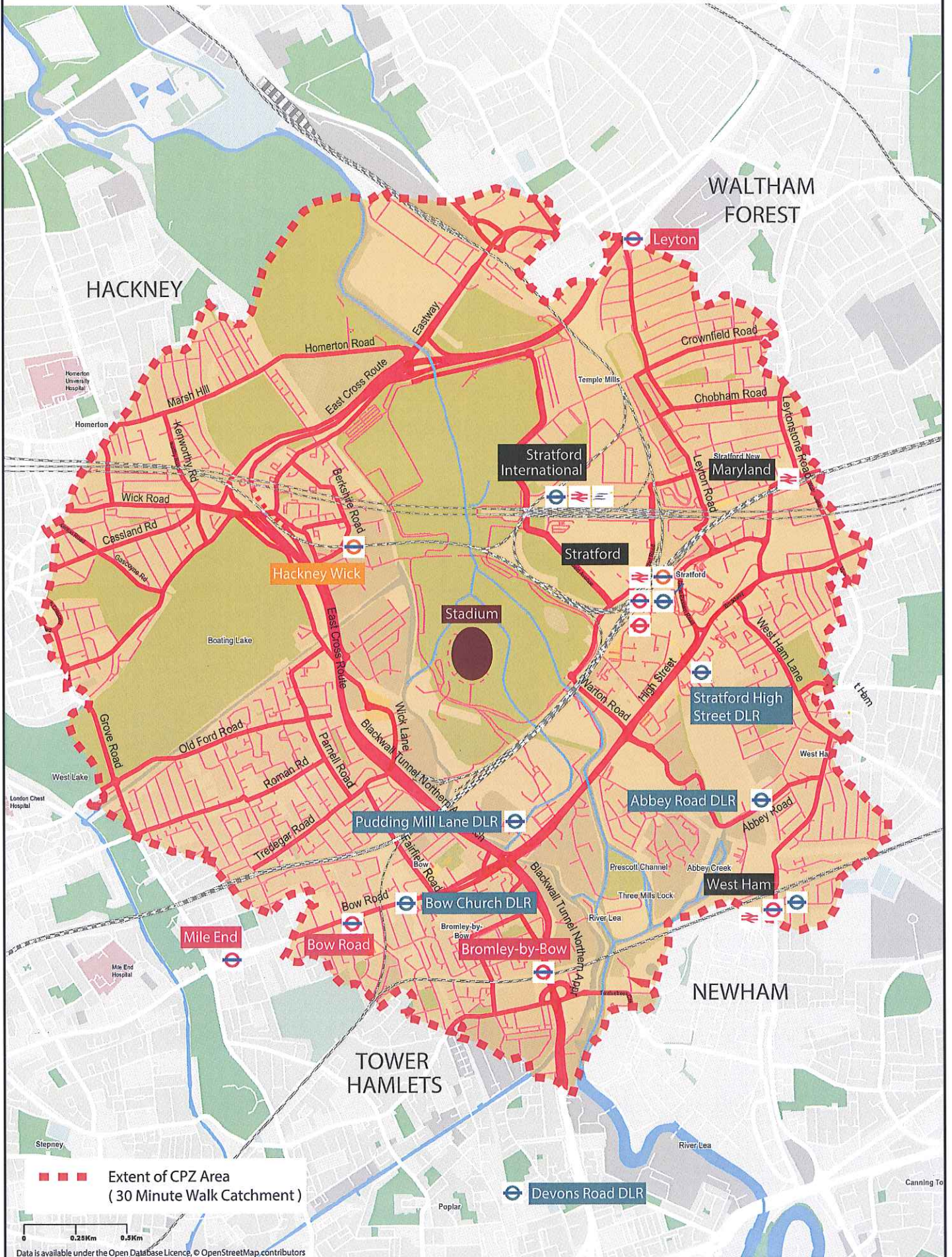

APPENDIX 10
EXTENT OF GREENWAY

Olympic Stadium Transformation

Extent of Greenway

JFS cut

X&D

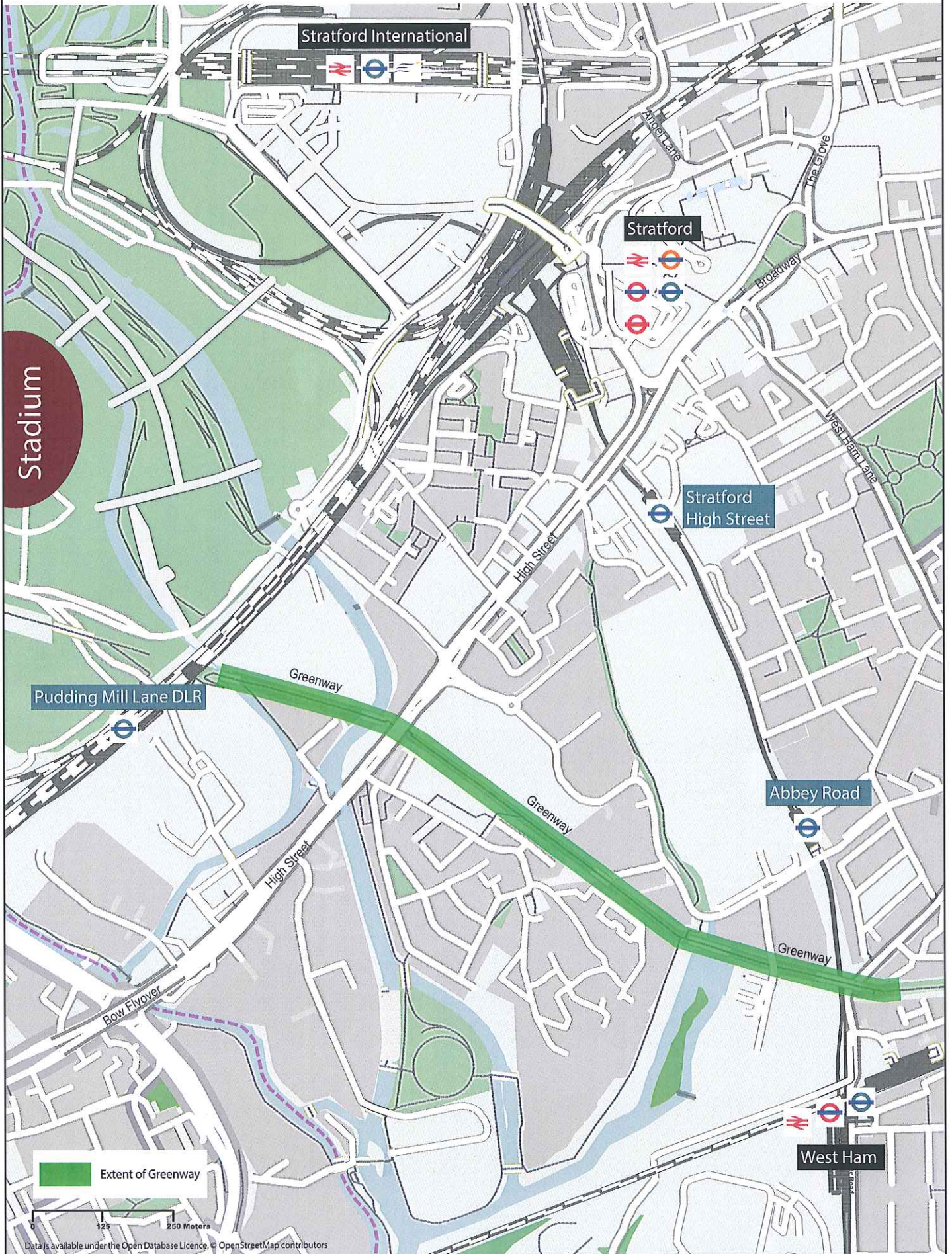

APPENDIX 11
KEY UNDERGROUND AND RAIL ROUTES

JCS cut *2-D

Key Underground & Rail Routes

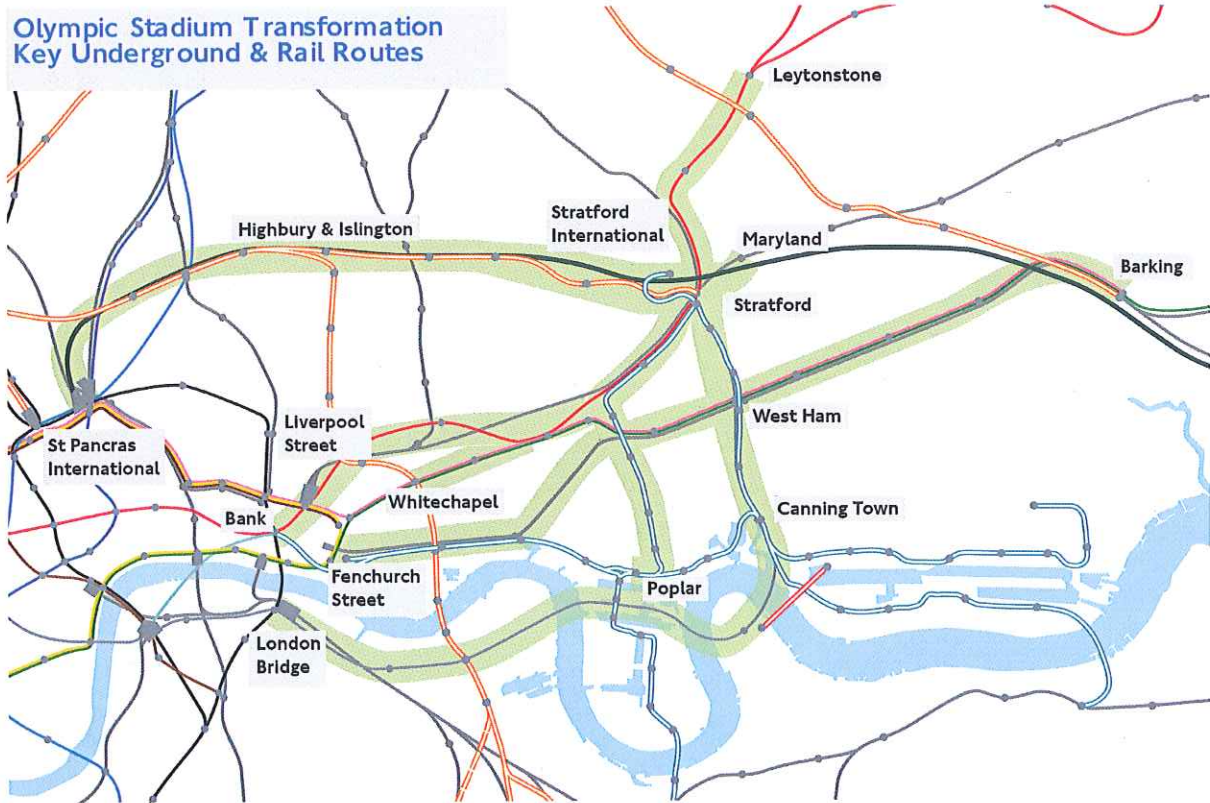

Via Stratford Regional

- Central line Bank to Leytonstone
- Jubilee line Stratford to London Bridge
- London Overground Stratford to Highbury & Islington
- National Rail Liverpool Street to Maryland

Via Stratford International

- National Rail St Pancras International to Stratford International

Via West Ham

- District / Hammersmith & City lines Whitechapel to Barking
- National Rail Fenchurch Street to Barking

Docklands Light Railway

- Stratford International to Canning Town
- Stratford Regional to Poplar

APPENDIX 12

KEY BUS ROUTE MONITORING AREA

Olympic Stadium Transformation

Key Bus Route Monitoring Area

JS *cl* *XJD*

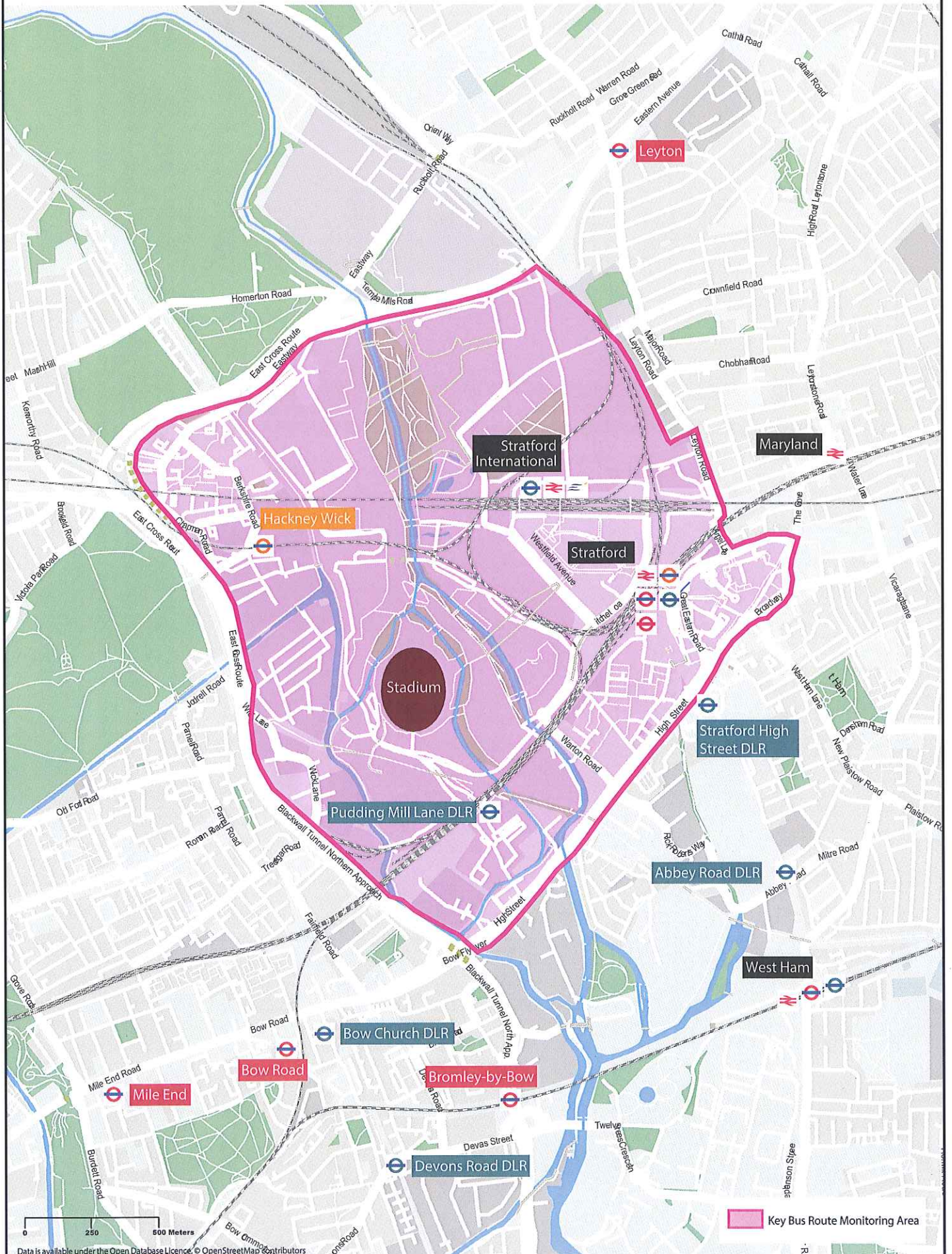

APPENDIX 13

ILLUSTRATION OF IN-CHANNEL WALL MOUNTED REED PLANTERS

JCB
Cont *X* *1*

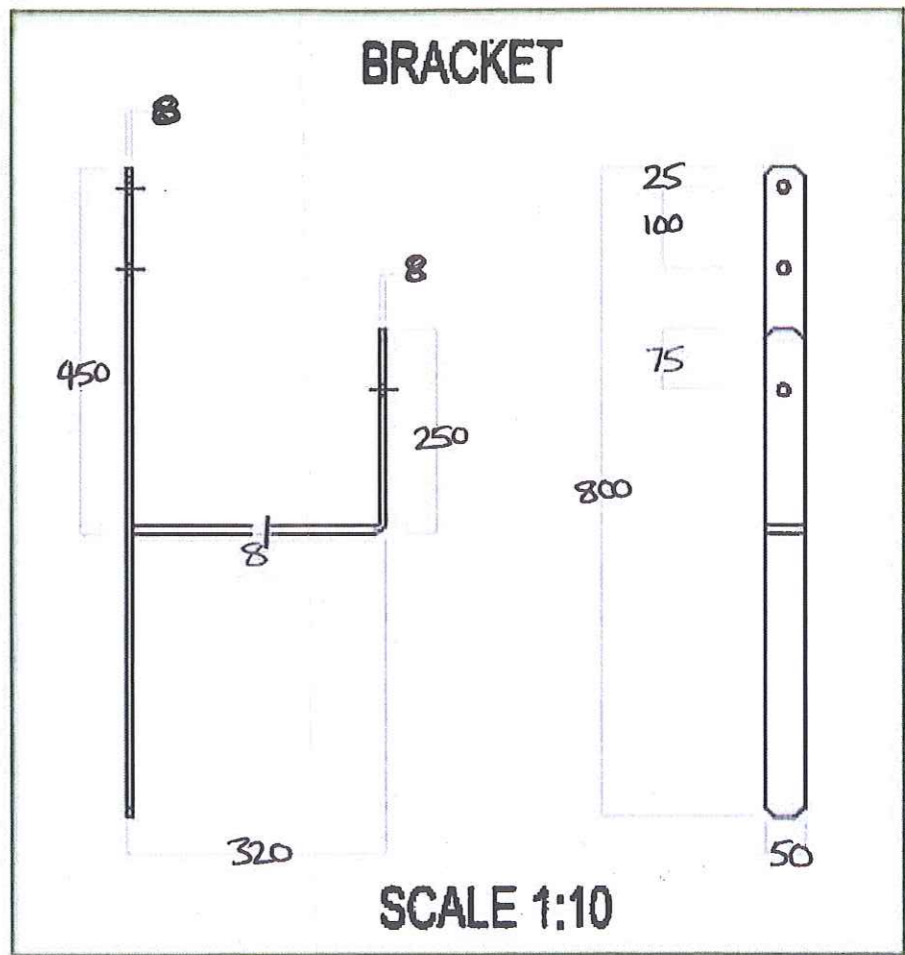
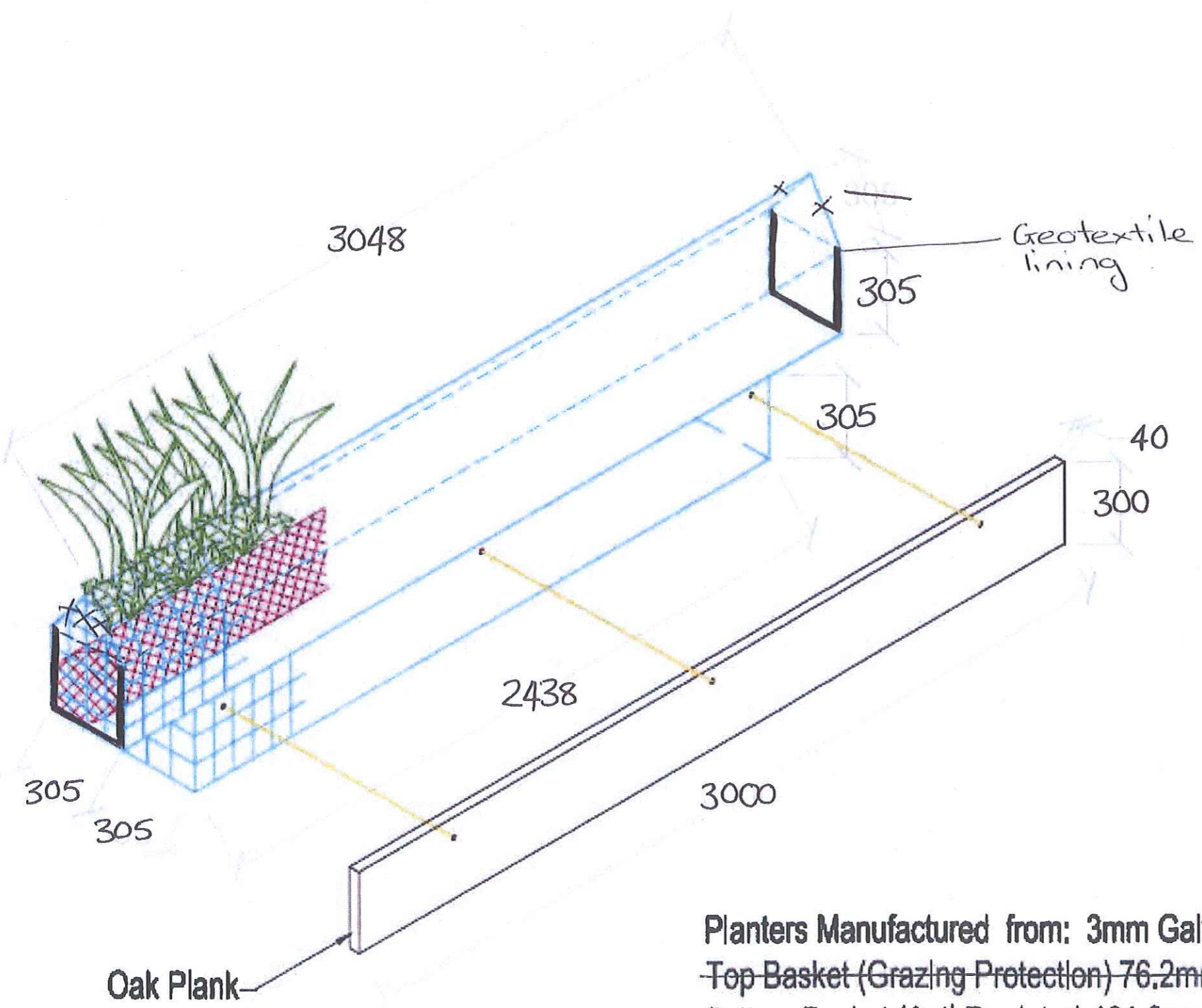





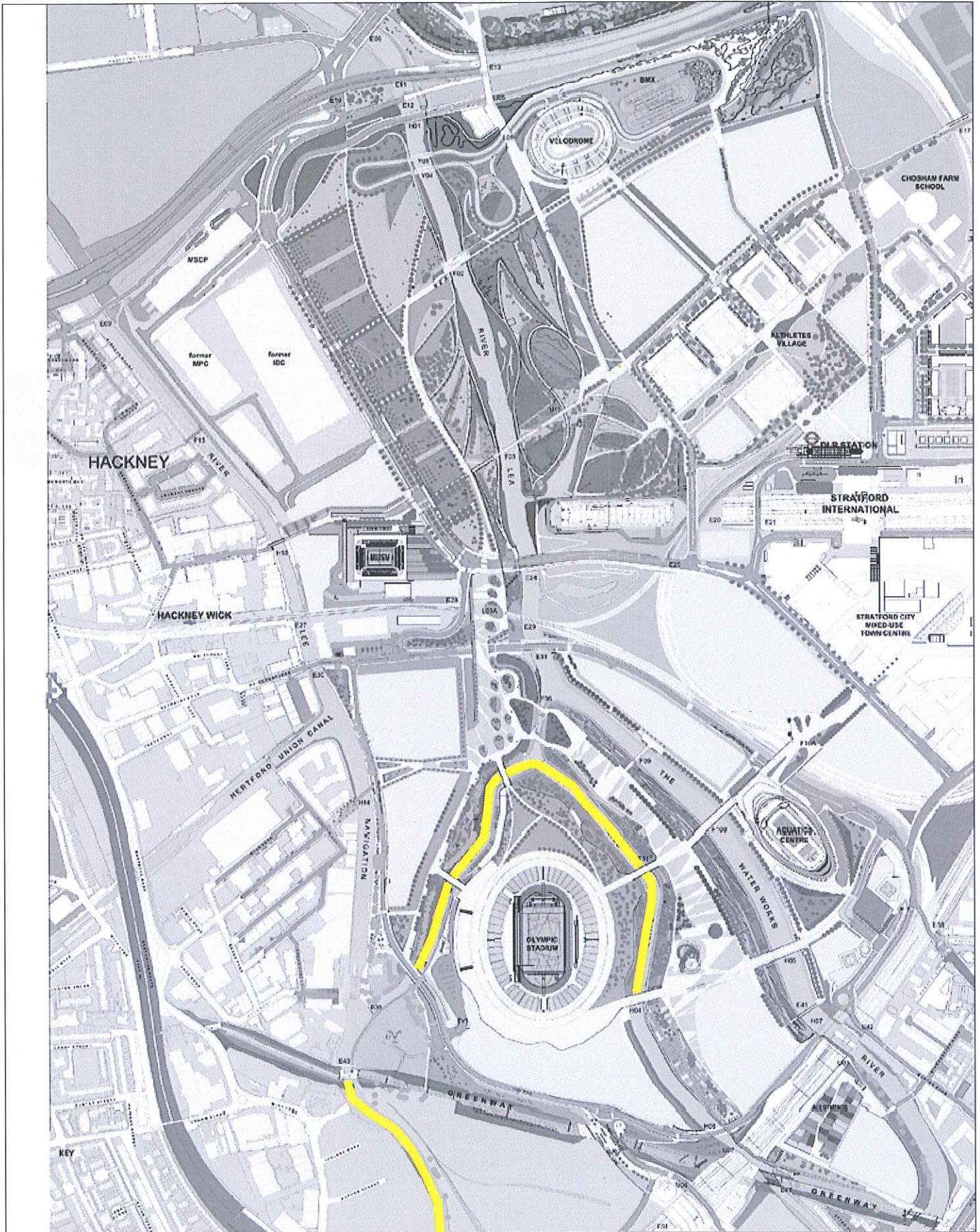

Planters Manufactured from: 3mm Galvanized Welded Mesh
 Top Basket (Grazing Protection) 76.2mm x 76.2mm Mesh Opening
 Bottom Basket (Anti-Predator) 101.6mm x 101.6mm Mesh Opening
 Geotextile lining 3m x 1m
 Preplanted coir 3m length @ 300mm roll.

NONE REQ.

Revisions:		
Date:	For:	Details:

APPENDIX 14
COMPENSATORY HABITAT PLAN



Key  COMPENSATORY HABITAT MAY BE PLANTED 	 	Client 	Drawing Title Olympic Park Compensatory Habitat	
		Organisation	Date 29/07/2013	Status For Information
Project Title	Figure No.	Drg. No.	Rev. 00	